

STATEMENT OF USE

THIS DOCUMENT AND ANY ILLUSTRATIONS HEREON ARE PROVIDED AS STANDARD CONSTRUCTION DETAILS WITHIN HOOPER CITY. DEVIATION FROM THIS DOCUMENT REQUIRES APPROVAL OF HOOPER CITY. HOOPER CITY CORPORATION CAN NOT BE HELD LIABLE FOR MISUSE OR CHANGES REGARDING THIS DOCUMENT.

REVISION

NO.	DESCRIPTION	BY	APR.	DATE



STANDARD URBAN STREET INTERSECTION & UTILITY LOCATIONS

HOOPER CITY
DEVELOPMENT STANDARDS

STANDARD DRAWING NUMBER: **1**

CAD DWG: STREET_IMP_PLN
PLOT SCALE: 1 = 1
DRAWN BY: JDM
DESIGN BY: TLA
CHECKED BY: TLA
ADOPTED DATENOV 2003

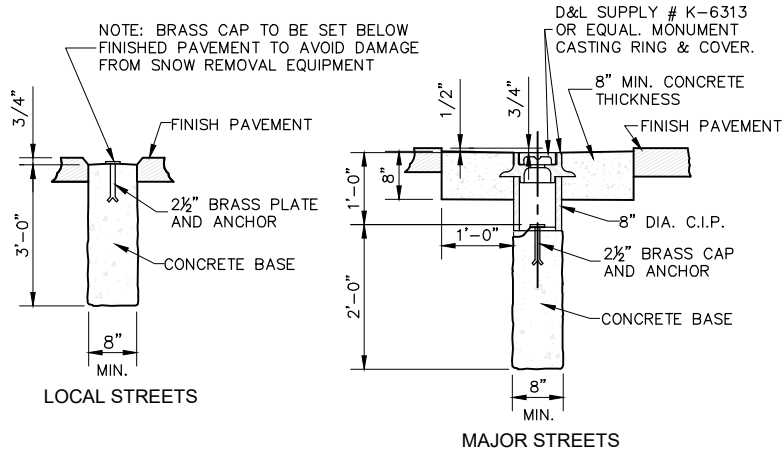

SURVEY MONUMENT SECTION
SCALE: N.T.S.

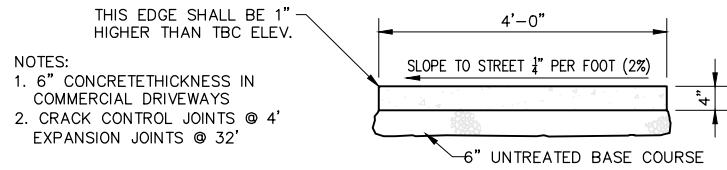

SIDEWALK SECTION
SCALE: N.T.S.

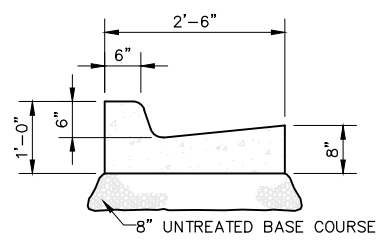

STANDARD CURB & SECTION
SCALE: N.T.S.

NOTES:
CRACK CONTROL JOINTS @ 10'
EXPANSION JOINTS @ 50'

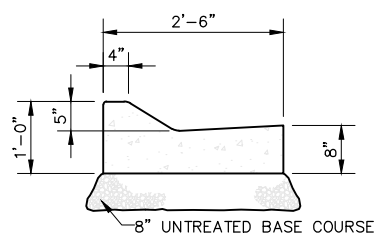

MODIFIED CURB & GUTTER SECTION (LOCAL STREETS ONLY)
SCALE: N.T.S.

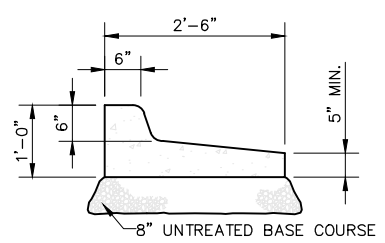

STANDARD SPILL CURB & SECTION
SCALE: N.T.S.

NOTES:
CRACK CONTROL JOINTS @ 10'
EXPANSION JOINTS @ 50'

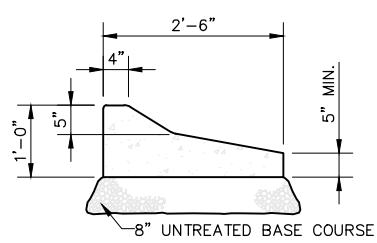

MODIFIED SPILL CURB & GUTTER SECTION (LOCAL STREETS ONLY)
SCALE: N.T.S.

STATEMENT OF USE

THIS DOCUMENT AND ANY ILLUSTRATIONS HEREON ARE PROVIDED AS STANDARD CONSTRUCTION DETAILS WITHIN HOOPER CITY. DEVIATION FROM THIS DOCUMENT REQUIRES APPROVAL OF HOOPER CITY. HOOPER CITY CORPORATION CAN NOT BE HELD LIABLE FOR MISUSE OR CHANGES REGARDING THIS DOCUMENT.

REVISION			
NO.	DESCRIPTION	BY	APR. DATE



STREET IMPROVEMENT SECTIONS

HOOPER CITY DEVELOPMENT STANDARDS

STANDARD DRAWING NUMBER:	2A
CAD DWG: STREET_IMP_SEC	
PLOT SCALE:	1 = 32
DRAWN BY:	JDM
DESIGN BY:	TLA
CHECKED BY:	TLA
ADOPTED DATE:	NOV 2005

NOTE:
CONTRACTION JOINTS EVERY 10' MAXIMUM
AND EXPANSION JOINTS EVERY 50' MAXIMUM

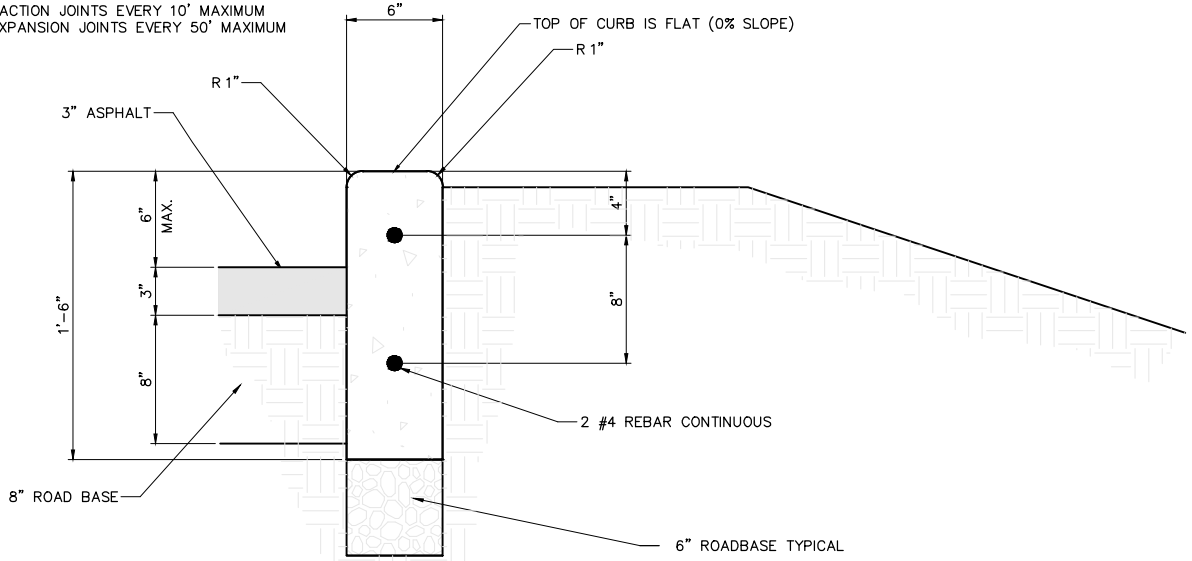

TYPICAL 18" CONCRETE CURB

SCALE: N.T.S.

NOTE:
CONTRACTION JOINTS EVERY 10' MAXIMUM
AND EXPANSION JOINTS EVERY 50' MAXIMUM

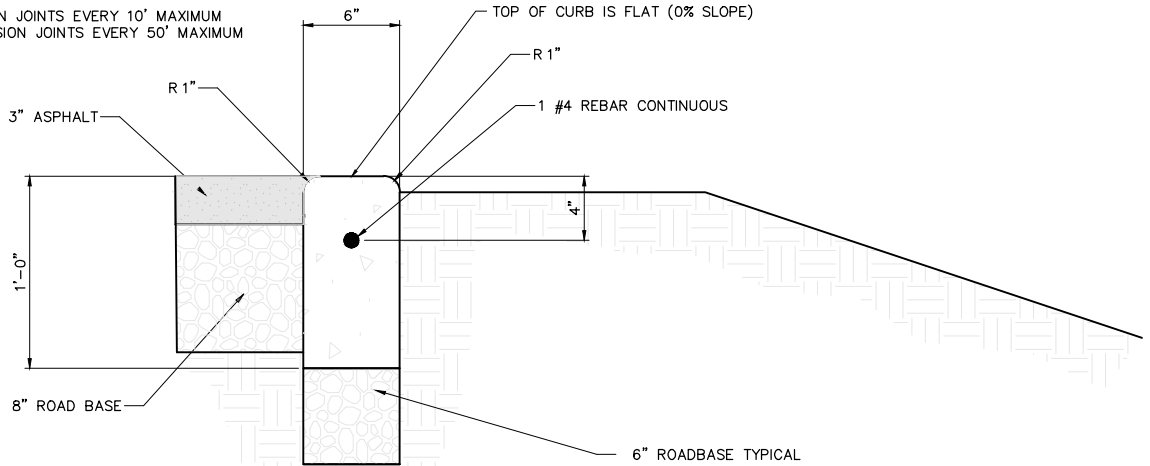

TYPICAL 12" CONCRETE CURB

SCALE: N.T.S.

NOTES:
CONSTRUCTION & EXPANSION JOINTS @ 5'
EXPANSION JOINTS @ EDGE OF APRON

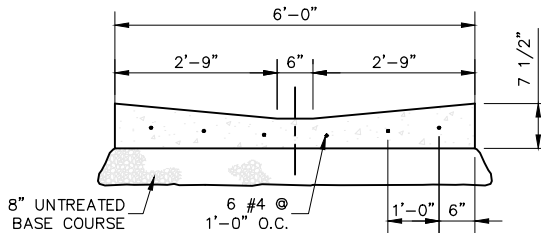

NOTE:
THIS STANDARD TO BE USED ONLY WHERE
APPROVED BY HOOPER CITY PUBLIC WORKS.

CROSS DRAIN SECTION

SCALE: N.T.S.

STATEMENT OF USE

THIS DOCUMENT AND ANY ILLUSTRATIONS HEREON ARE PROVIDED AS STANDARD CONSTRUCTION DETAILS WITHIN HOOPER CITY. DEVIATION FROM THIS DOCUMENT REQUIRES APPROVAL OF HOOPER CITY. HOOPER CITY CORPORATION CAN NOT BE HELD LIABLE FOR MISUSE OR CHANGES REGARDING THIS DOCUMENT.

REVISION

NO.	DESCRIPTION	BY	APR.	DATE
▲				
▲				
▲				



STREET IMPROVEMENT SECTIONS

HOOPER CITY
DEVELOPMENT STANDARDS

STANDARD DRAWING NUMBER: **2B**

CAD DWG: STREET_IMP_SEC
PLOT SCALE: 1 = 32
DRAWN BY: JDM
DESIGN BY: TLA
CHECKED BY: TLA
ADOPTED DATE: NOV 2005

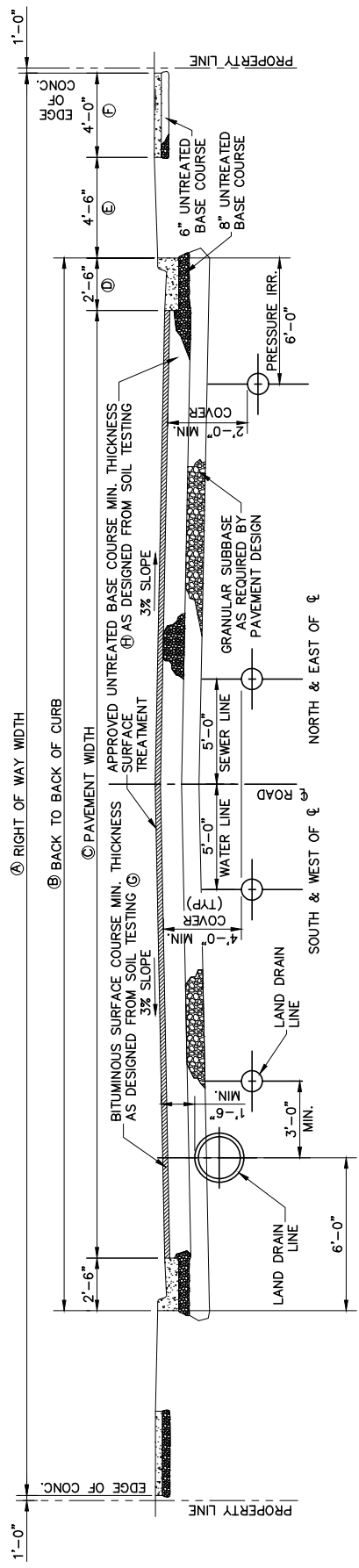

- NOTES:
1. TOP BACK OF CURB ON BOTH SIDES OF ROAD TO BE SAME ELEVATIONS.
 2. THE CITY ENGINEER SHALL VERIFY PAVEMENT DESIGN PRESCRIBED BY SOILS REPORT. (SEE SPECIFICATIONS)
 3. COMMERCIAL AND INDUSTRIAL STREET SECTIONS ARE DETERMINED BASED ON A TRAFFIC ANALYSIS FOR THE PARTICULAR USE.

STREET DESIGNATION	A	B	C	D	E	F	G	H
ARTERIAL	UDOT	UDOT	UDOT	UDOT	4.5'	4.0'	NOTE 2	NOTE 2
SECONDARY ARTERIAL	84'	65'	60'	2.5'	4.5'	4.0'	NOTE 2	NOTE 2

STANDARD ARTERIAL STREET SECTION

STATEMENT OF USE

THIS DOCUMENT AND ANY ILLUSTRATIONS HEREON ARE PROVIDED AS STANDARD CONSTRUCTION DETAILS WITHIN HOOPER CITY. DEVIATION FROM THIS DOCUMENT REQUIRES APPROVAL OF HOOPER CITY. HOOPER CITY CORPORATION CAN NOT BE HELD LIABLE FOR MISUSE OR CHANGES REGARDING THIS DOCUMENT.

REVISION	NO.	DESCRIPTION	BY	APR.	DATE



STANDARD ARTERIAL STREET SECTION

HOOPER CITY DEVELOPMENT STANDARDS

STANDARD DRAWING NUMBER:	3
CAD DWG: STREET_SEC_C&C	
PLOT SCALE:	1 = 1
DRAWN BY:	JDM
DESIGN BY:	TLA
CHECKED BY:	TLA
ADOPTED DATE:	NOV 2003

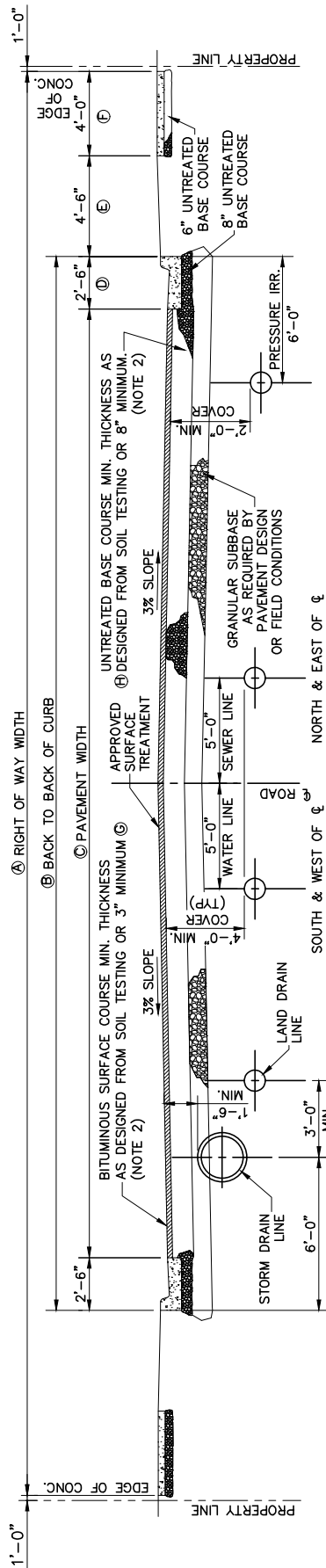

- NOTES:
1. TOP BACK OF CURB ON BOTH SIDES OF ROAD TO BE SAME ELEVATIONS.
 2. THE CITY ENGINEER SHALL VERIFY PAVEMENT DESIGN PRESCRIBED BY SOILS REPORT. (SEE SPECIFICATIONS)
 3. COMMERCIAL AND INDUSTRIAL STREET SECTIONS ARE DETERMINED BASED ON A TRAFFIC ANALYSIS FOR THE PARTICULAR USE.

STREET DESIGNATION	Ⓐ	Ⓑ	Ⓒ	Ⓓ	Ⓔ	Ⓕ	Ⓖ	Ⓗ
COLLECTOR	66'	47'	42'	2.5'	4.5'	4.0'	3" MIN.	8" MIN.
LOCAL	60'	41'	36'	2.5'	4.5'	4.0'	3" MIN.	8" MIN.

STANDARD STREET SECTION WITH CURB & GUTTER

STATEMENT OF USE

THIS DOCUMENT AND ANY ILLUSTRATIONS HEREON ARE PROVIDED AS STANDARD CONSTRUCTION DETAILS WITHIN HOOPER CITY. DEVIATION FROM THIS DOCUMENT REQUIRES APPROVAL OF HOOPER CITY. HOOPER CITY CORPORATION CAN NOT BE HELD LIABLE FOR MISUSE OR CHANGES REGARDING THIS DOCUMENT.

NO.	REVISION	BY	APR.	DATE



STANDARD STREET SECTION WITH CURB & GUTTER

HOOPER CITY DEVELOPMENT STANDARDS

STANDARD DRAWING NUMBER:	4A
CAD DWG STREET_SEC_RURAL	
PLOT SCALE:	1 = 1
DRAWN BY:	JDM
DESIGN BY:	TLA
CHECKED BY:	TLA
ADOPTED DATE:	NOV 2003

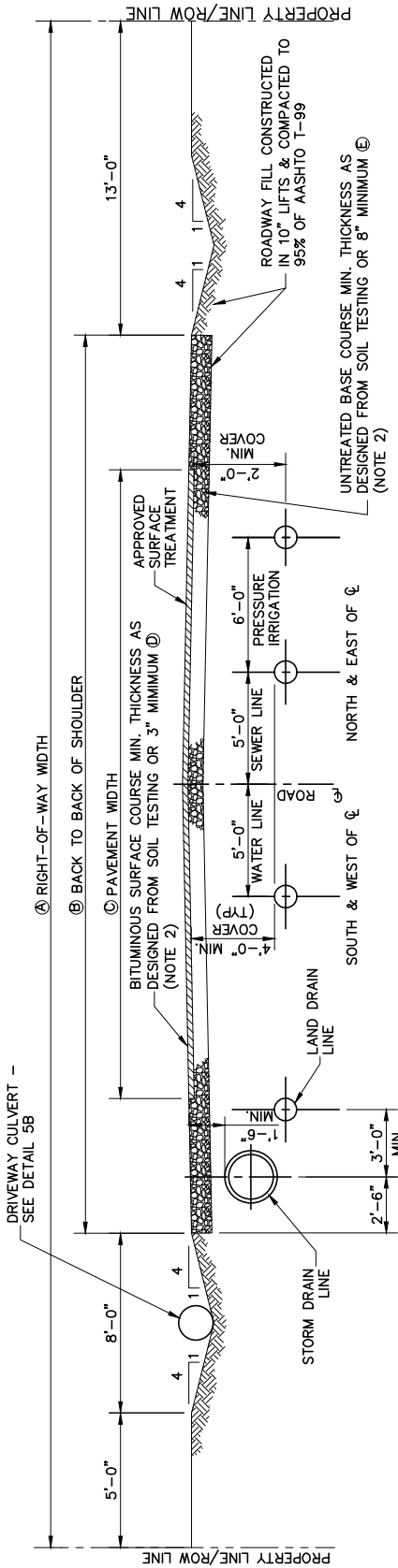

STREET DESIGNATION	A	B	C	D	E
COLLECTOR	66'	40'	28'	3" MIN.	18" MIN.
LOCAL	60'	34'	24'	3" MIN.	18" MIN.

- NOTES:
1. BACK OF SHOULDER ON BOTH SIDES OF ROAD TO BE SAME ELEVATIONS.
 2. THE CITY ENGINEER SHALL VERIFY PAVEMENT DESIGN PRESCRIBED BY SOILS REPORT. (SEE SPECIFICATIONS).
 3. COMMERCIAL AND INDUSTRIAL STREET SECTIONS ARE DETERMINED BASED ON A TRAFFIC ANALYSIS FOR THE PARTICULAR USE.

**STANDARD RURAL STREET SECTION WITHOUT CURB & GUTTER
(EXISTING STREETS ONLY - NOT FOR NEW DEVELOPMENT)**

STATEMENT OF USE

THIS DOCUMENT AND ANY ILLUSTRATIONS HEREON ARE PROVIDED AS STANDARD CONSTRUCTION DETAILS WITHIN HOOPER CITY. DEVIATION FROM THIS DOCUMENT REQUIRES APPROVAL OF HOOPER CITY. HOOPER CITY CORPORATION CAN NOT BE HELD LIABLE FOR MISUSE OR CHANGES REGARDING THIS DOCUMENT.

NO.	REVISION	DESCRIPTION	BY	APR.	DATE



**STANDARD RURAL STREET SECTION
WITHOUT CURB & GUTTER**

HOOPER CITY
DEVELOPMENT STANDARDS

STANDARD DRAWING NUMBER: **4B**

CAD DWG: STREET_SEC_SWA

PLOT SCALE: 1 = 1

DRAWN BY: JDM

DESIGN BY: TLA

CHECKED BY: TLA

ADOPTED DATE: NOV 2003

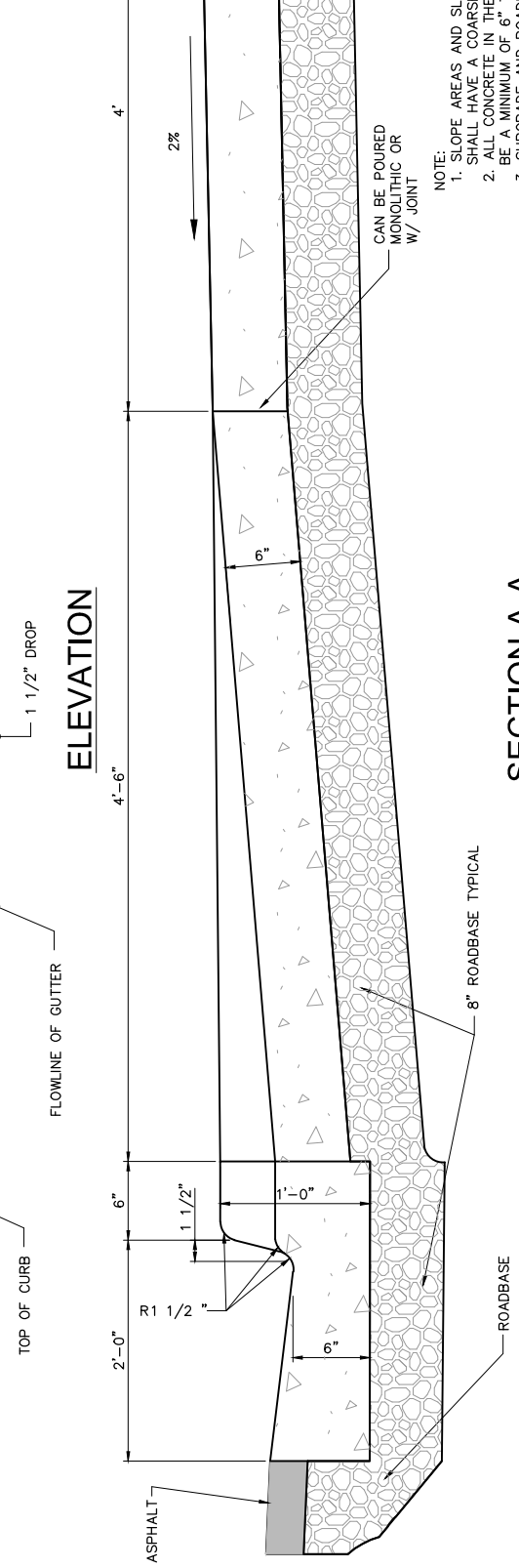
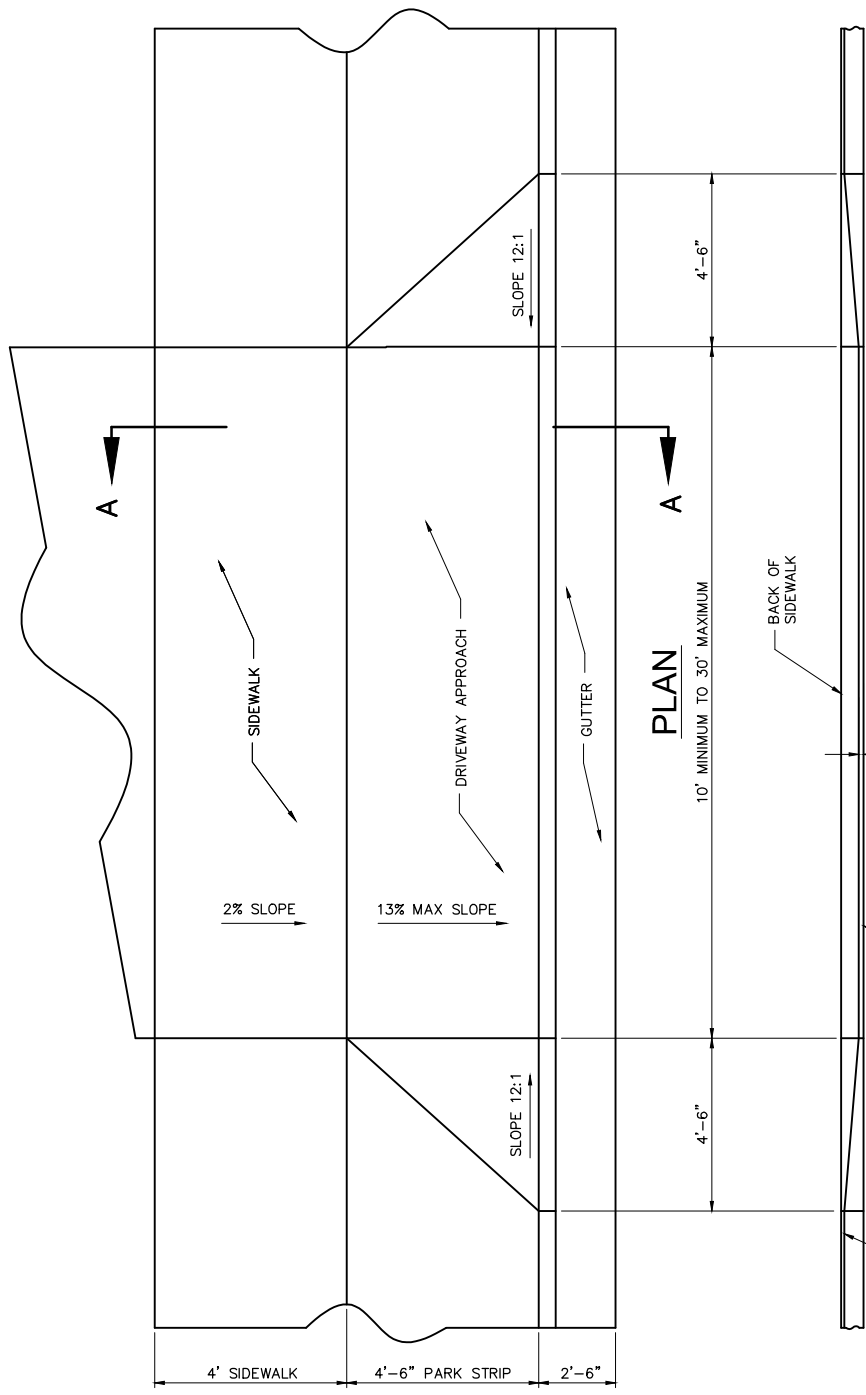

NOTE:
 1. SLOPE AREAS AND SLOPE DRIVEWAYS SHALL HAVE A COARSE BROOM FINISH
 2. ALL CONCRETE IN THE DRIVEWAY SHALL BE A MINIMUM OF 6" THICK
 3. SUBGRADE AND ROADBASE COMPACTION TESTING IS REQUIRED FOR DRIVEWAYS.

SECTION A-A

STATEMENT OF USE
 THIS DOCUMENT AND ANY ILLUSTRATIONS HEREON ARE PROVIDED AS STANDARD CONSTRUCTION DETAILS WITHIN HOOPER CITY. DEVIATION FROM THIS DOCUMENT REQUIRES APPROVAL OF HOOPER CITY. HOOPER CITY CORPORATION CAN NOT BE HELD LIABLE FOR MISUSE OR CHANGES REGARDING THIS DOCUMENT.

REVISION			
NO.	DESCRIPTION	BY	DATE



RESIDENTIAL DRIVEWAY DETAILS

HOOPER CITY
 DEVELOPMENT STANDARDS

STANDARD DRAWING NUMBER: **5A**

CAD DWG: STREET_IMP_SEC
 PLOT SCALE: 1 = 1
 DRAWN BY: JDM
 DESIGN BY: TLA
 CHECKED BY: TLA
 ADOPTED DATE: NOV 2005

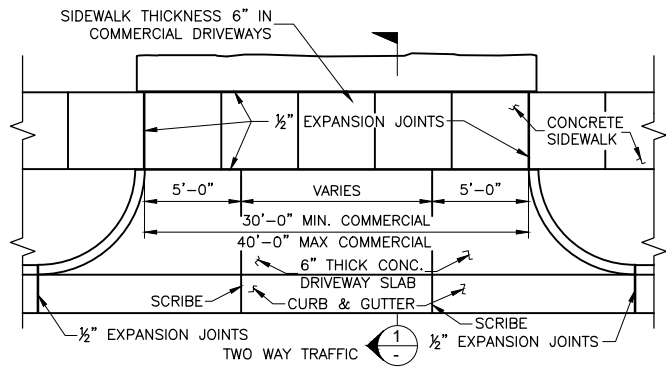
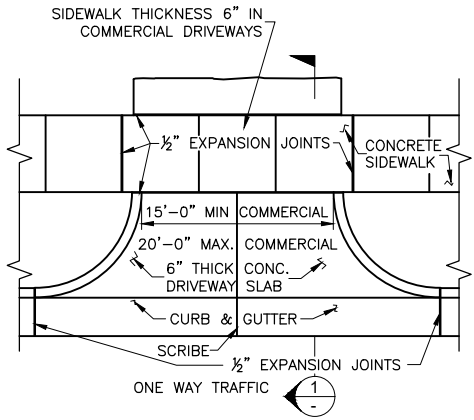

TYPE 1 DRIVEWAY APPROACH
PREFERRED STYLE FOR COMMERCIAL DEVELOPMENT

NOTE:
SCRIBE SIDEWALK 1/2" DEPTH AT EACH 4'-0"
EXPANSION JOINT AT EACH 32'-0"
CURB & GUTTER EXPANSION JOINT AT EACH 50'
CURB & GUTTER CONSTRUCTION JOINT AT EACH 10'

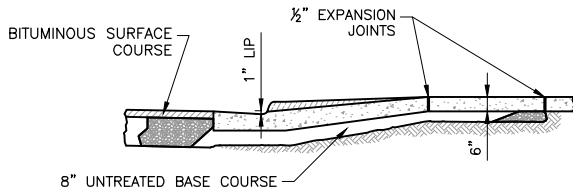

SECTION 1
SCALE: N.T.S.

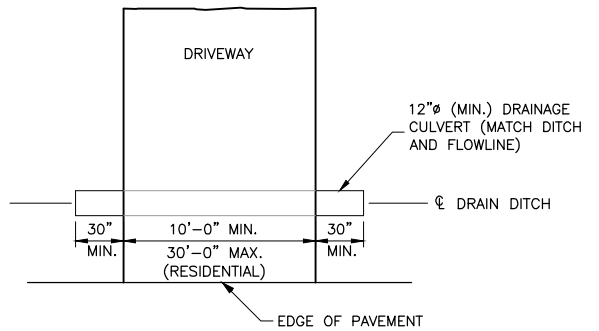

TYPE 2 DRIVEWAY APPROACH
TYPICAL ON EXISTING SWALE DRAINAGE FACILITIES - NOT FOR NEW DEVELOPMENT

STATEMENT OF USE
THIS DOCUMENT AND ANY ILLUSTRATIONS HEREON ARE PROVIDED AS STANDARD CONSTRUCTION DETAILS WITHIN HOOPER CITY. DEVIATION FROM THIS DOCUMENT REQUIRES APPROVAL OF HOOPER CITY. HOOPER CITY CORPORATION CAN NOT BE HELD LIABLE FOR MISUSE OR CHANGES REGARDING THIS DOCUMENT.

REVISION			
NO.	DESCRIPTION	BY	APR. DATE



DRIVEWAY DETAILS

HOOPER CITY
DEVELOPMENT STANDARDS

STANDARD DRAWING NUMBER: **5B**

CAD DWG: DRIVEWAY_DET
PLOT SCALE: 1 = 1
DRAWN BY: JDM
DESIGN BY: TLA
CHECKED BY: TLA
ADOPTED DATE: NOV 2005

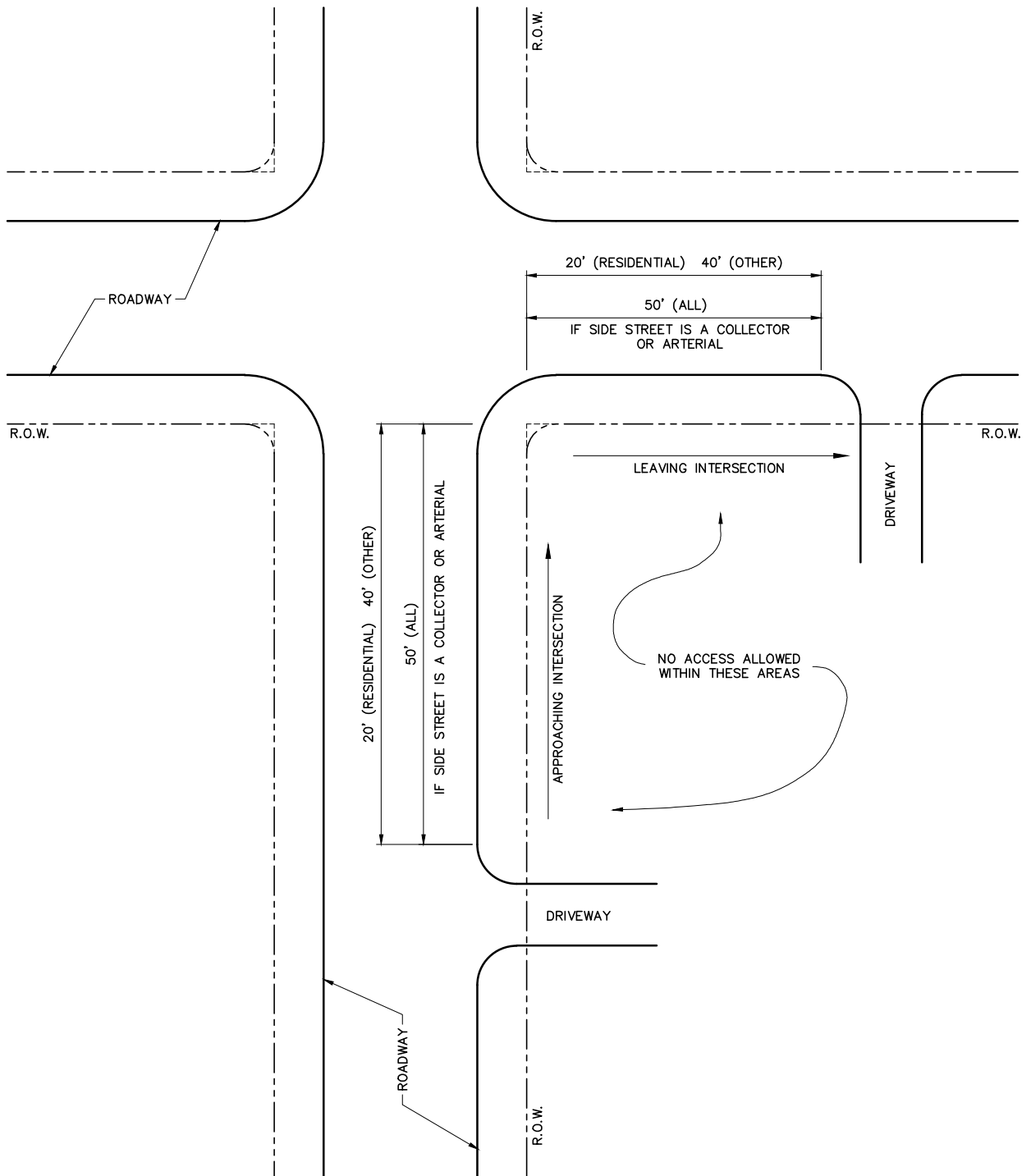

STATEMENT OF USE

THIS DOCUMENT AND ANY ILLUSTRATIONS HEREON ARE PROVIDED AS STANDARD CONSTRUCTION DETAILS WITHIN HOOPER CITY. DEVIATION FROM THIS DOCUMENT REQUIRES APPROVAL OF HOOPER CITY. HOOPER CITY CORPORATION CAN NOT BE HELD LIABLE FOR MISUSE OR CHANGES REGARDING THIS DOCUMENT.

REVISION

NO.	DESCRIPTION	BY	APR.	DATE



CONTROL OF ACCESS LIMITATIONS

HOOPER CITY
DEVELOPMENT STANDARDS

STANDARD DRAWING NUMBER: **5C**

CAD DWG: RES_CONTROL_ACCESS
PLOT SCALE: 1 = 2
DRAWN BY: JDM
DESIGN BY: TLA
CHECKED BY: TLA
ADOPTED DATE: DEC. 2016

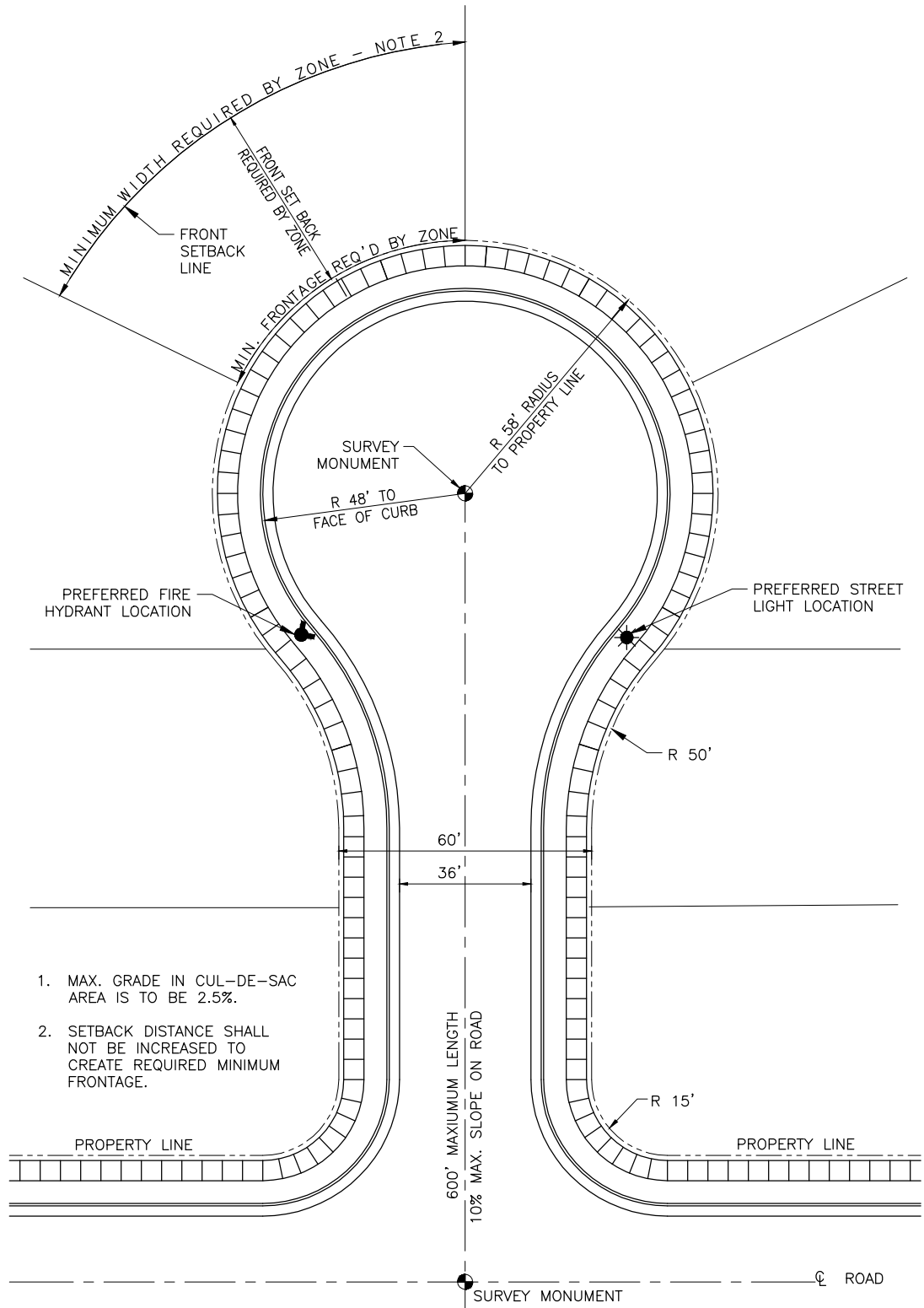

1. MAX. GRADE IN CUL-DE-SAC AREA IS TO BE 2.5%.
2. SETBACK DISTANCE SHALL NOT BE INCREASED TO CREATE REQUIRED MINIMUM FRONTAGE.

STANDARD CUL-DE-SAC

SCALE: N.T.S.

STATEMENT OF USE

THIS DOCUMENT AND ANY ILLUSTRATIONS HEREON ARE PROVIDED AS STANDARD CONSTRUCTION DETAILS WITHIN HOOPER CITY. DEVIATION FROM THIS DOCUMENT REQUIRES APPROVAL OF HOOPER CITY. HOOPER CITY CORPORATION CAN NOT BE HELD LIABLE FOR MISUSE OR CHANGES REGARDING THIS DOCUMENT.

REVISION

NO.	DESCRIPTION	BY	APR.	DATE



J-U-B ENGINEERS, INC.

STANDARD CUL-DE-SAC

HOOPER CITY
DEVELOPMENT STANDARDS

STANDARD DRAWING NUMBER: **6A**

CAD DWG: STREET_IMP_SEC
PLOT SCALE: 1 = 1
DRAWN BY: JDM
DESIGN BY: TLA
CHECKED BY: TLA
ADOPTED DATE: XX

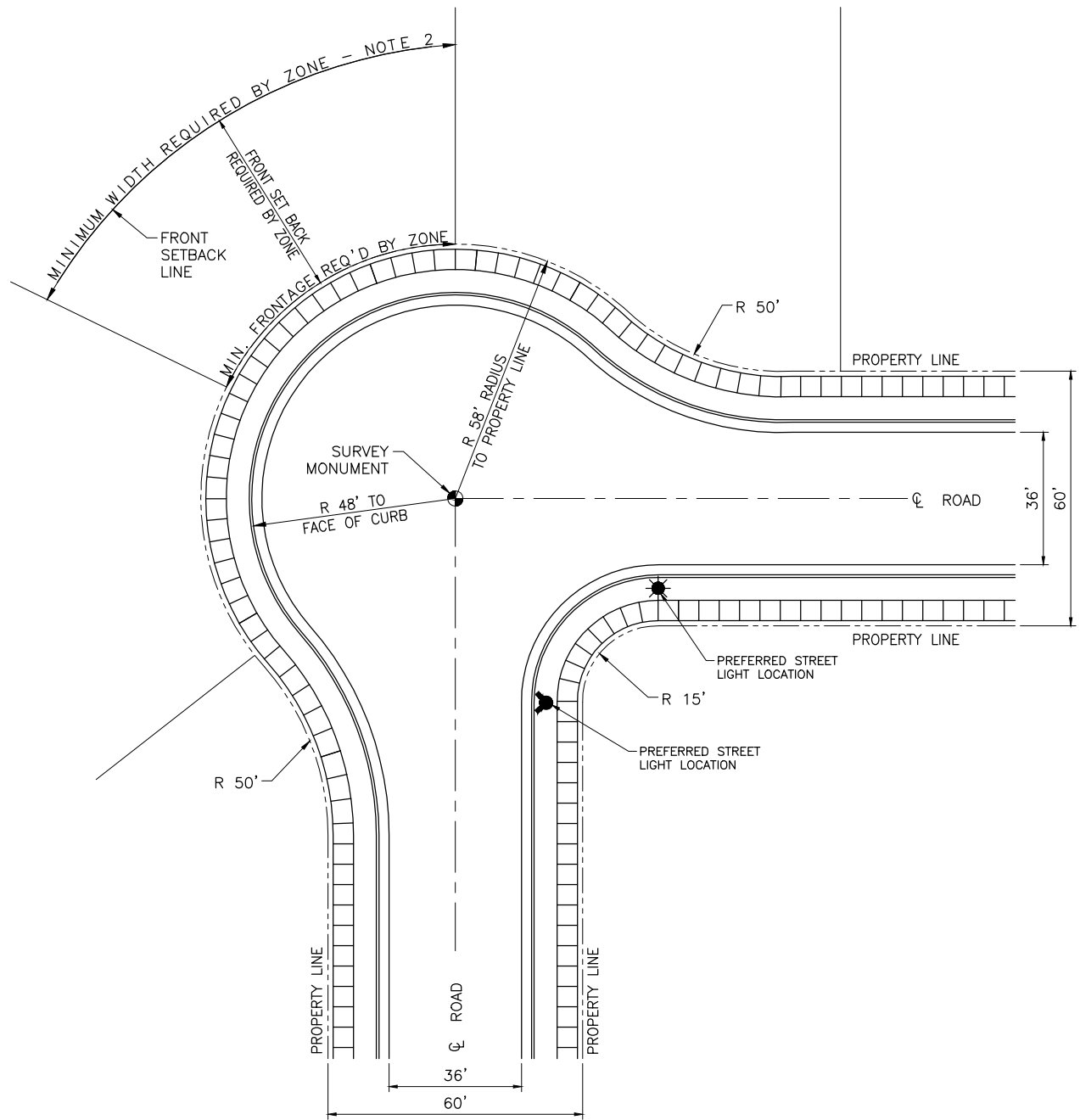

STANDARD KNUCKLE
SCALE: N.T.S.

STATEMENT OF USE

THIS DOCUMENT AND ANY ILLUSTRATIONS HEREON ARE PROVIDED AS STANDARD CONSTRUCTION DETAILS WITHIN HOOPER CITY. DEVIATION FROM THIS DOCUMENT REQUIRES APPROVAL OF HOOPER CITY. HOOPER CITY CORPORATION CAN NOT BE HELD LIABLE FOR MISUSE OR CHANGES REGARDING THIS DOCUMENT.

REVISION

NO.	DESCRIPTION	BY	APR.	DATE
▲				
▲				
▲				



J-U-B ENGINEERS, INC.

**STANDARD KNUCKLE AND
TEMPORARY TURN-AROUND**

**HOOPER CITY
DEVELOPMENT STANDARDS**

STANDARD DRAWING NUMBER: **6B**

CAD DWG: STREET_IMP_SEC
PLOT SCALE: 1 = 1
DRAWN BY: JDM
DESIGN BY: TLA
CHECKED BY: TLA
ADOPTED DATE: XX

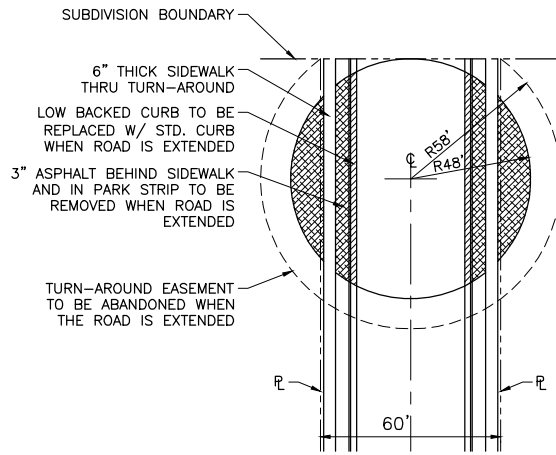

- NOTE:
1. IMPROVED TEMPORARY TURN-AROUND WILL BE REQUIRED WHEN THE PERMANENT STREET IS PLANNED TO CONTINUE AND THE ADJACENT PROPERTY IS NOT OWNED BY THE CURRENT DEVELOPER OR IS NOT PLANNED FOR IMMEDIATE DEVELOPMENT.
 2. WHEN A IMPROVED TEMPORARY TURN-AROUND IS CONSTRUCTED, THE SUBDIVIDER MUST PLACE IN ESCROW THE AMOUNT OF MONEY SUFFICIENT TO REMOVE AND REPLACE THE LOW-BACK CURB & GUTTER, THE PAVEMENT LOCATED BEHIND THE PARK STRIP AND THE PAVEMENT LOCATED BEHIND THE SIDEWALK. THESE FUNDS WILL BE USED WHEN THE STREET IS EXTENDED.
 3. LOTS ASSOCIATED WITH THE IMPROVED TEMPORARY TURN-AROUND SHALL BE LABELED "RESTRICTED" ON THE PLAT WITH NO ON STREET PARKING AND NO ABOVE-GRADE STRUCTURES IN THE TURN-AROUND AREA.

IMPROVED TEMPORARY TURN-AROUND
SCALE: N.T.S.

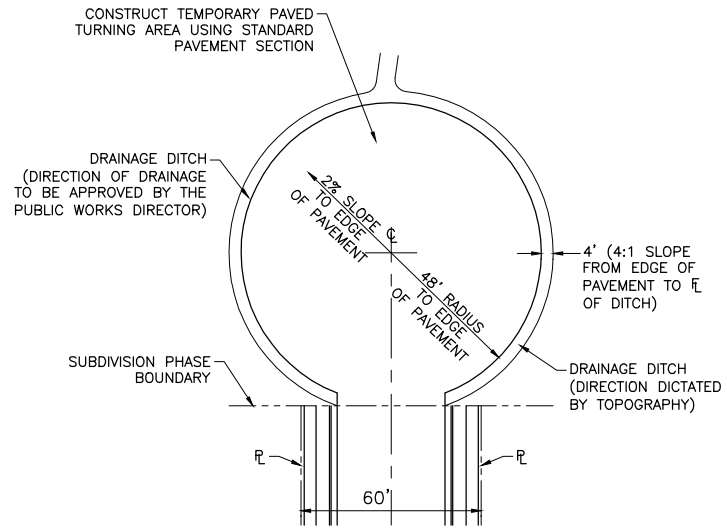

- NOTES:
1. PAVED TEMPORARY TURN-AROUND WILL BE PERMITTED WHEN THE PERMANENT STREET IS PLANNED TO CONTINUE IN THE FUTURE AND THE PROPERTY ON WHICH THE TEMPORARY TURN-AROUND WILL BE BUILT IS OWNED BY THE DEVELOPER OF THE CURRENT DEVELOPMENT.

PAVED TEMPORARY TURN-AROUND
SCALE: N.T.S.

STATEMENT OF USE

THIS DOCUMENT AND ANY ILLUSTRATIONS HEREON ARE PROVIDED AS STANDARD CONSTRUCTION DETAILS WITHIN HOOPER CITY. DEVIATION FROM THIS DOCUMENT REQUIRES APPROVAL OF HOOPER CITY. HOOPER CITY CORPORATION CAN NOT BE HELD LIABLE FOR MISUSE OR CHANGES REGARDING THIS DOCUMENT.

REVISION			
NO.	DESCRIPTION	BY	APR. DATE



TEMPORARY TURN-AROUND

**HOOPER CITY
DEVELOPMENT STANDARDS**

STANDARD DRAWING NUMBER: **6C**

CAD DWG: STREET_IMP_SEC

PLOT SCALE: 1 = 1

DRAWN BY: JDM

DESIGN BY: TLA

CHECKED BY: TLA

ADOPTED DATE: XX

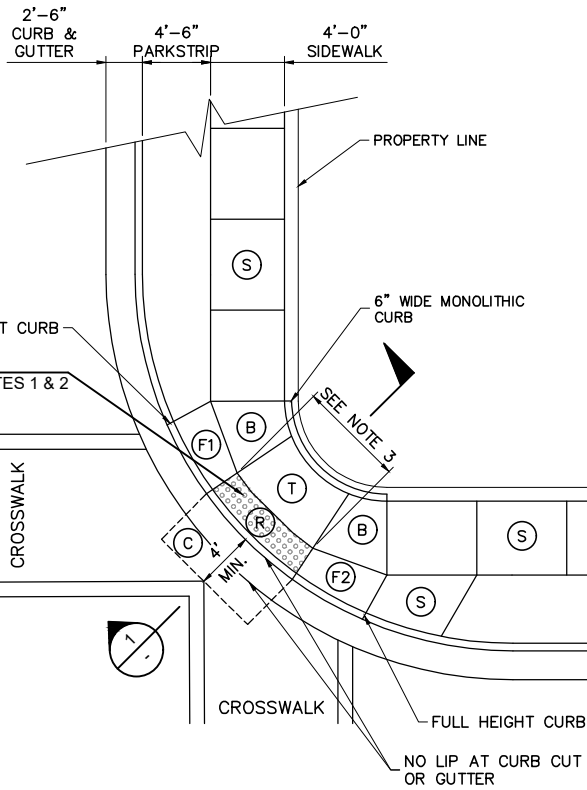

- NOTES:
1. LOCATE RAISED TRUNCATED DOMES SO THAT THE EDGE NEAREST THE CURB LINE IS WITHIN 6 TO 8 INCHES FROM THE CURB LINE. PROVIDE 2-FOOT OF TRUNCATED DOME PATTERN AT THE LOWER END OF ALL CURB RAMPS EXTENDING THE FULL WIDTH OF THE CURB RAMP.
 2. CHANGES IN ELEVATION GREATER THAN 1/4" SHALL BE BEVELED WITH A SLOPE NO GREATER THAN 2:1
 3. THE DETECTABLE WARNING SURFACE DOMES SHALL BE ORIENTED SUCH THAT THE ROWS ARE PARALLEL WITH THE DIRECTION OF PEDESTRIAN TRAVEL TO THE RAMP ON THE OPPOSITE SIDE OF THE STREET.
 4. THE STANDARD COLOR FOR THE DETECTABLE WARNING SHALL BE YELLOW. WHEN THE EXISTING SIDEWALK COLOR IS NOT STANDARD CONCRETE, THE COLOR OF THE DETECTABLE WARNING SURFACE SHALL BE DETERMINED BY HOOPER CITY.
 5. WHEN A DETECTABLE WARNING SURFACE DOME IS CUT, THE REMAINING PORTION OF THE DOME SHALL BE BEVELED TO A MAXIMUM SLOPE OF 1:2.
 6. INSTALLATION SHALL BE DONE IN ACCORDANCE WITH MANUFACTURER'S RECOMMENDATION.

A.D.A. WHEELCHAIR RAMP DETAIL

SCALE N.T.S.

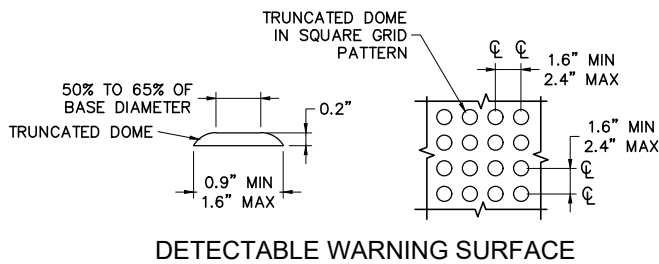

DETECTABLE WARNING SURFACE

DETAIL B

N.T.S.

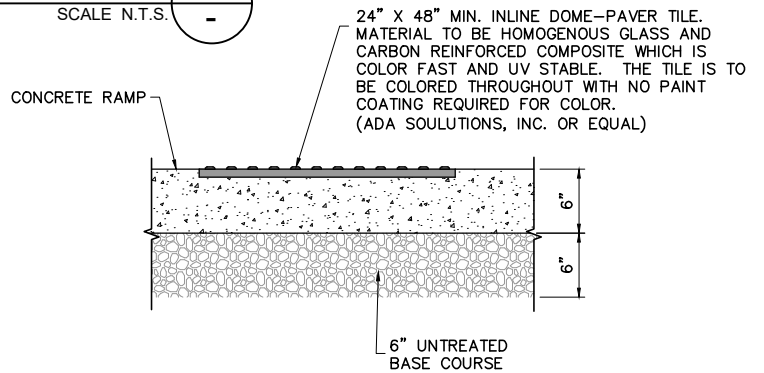

INLINE DOME PAVER TILE

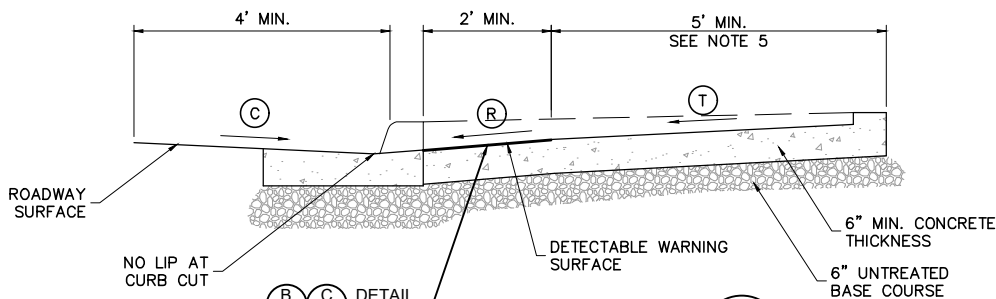

SECTION 1

N.T.S.

STATEMENT OF USE

THIS DOCUMENT AND ANY ILLUSTRATIONS HEREON ARE PROVIDED AS STANDARD CONSTRUCTION DETAILS WITHIN HOOPER CITY. DEVIATION FROM THIS DOCUMENT REQUIRES APPROVAL OF HOOPER CITY. HOOPER CITY CORPORATION CAN NOT BE HELD LIABLE FOR MISUSE OR CHANGES REGARDING THIS DOCUMENT.

REVISION

REVD PER NEW A.D.A. REQUIREMENTS	JDM	TLA	3/9/07
REVD DETECTABLE WARNING DETAIL	JDM	TLA	9/24/07
NO.	DESCRIPTION	BY	APR. DATE



WHEELCHAIR RAMP

HOOPER CITY
DEVELOPMENT STANDARDS

STANDARD DRAWING NUMBER: **7A**

CAD DWG: WHEELCHAIR_RAMP
PLOT SCALE: 1 = 2
DRAWN BY: JDM
DESIGN BY: TLA
CHECKED BY: TLA
ADOPTED DATE: SEP. 2004

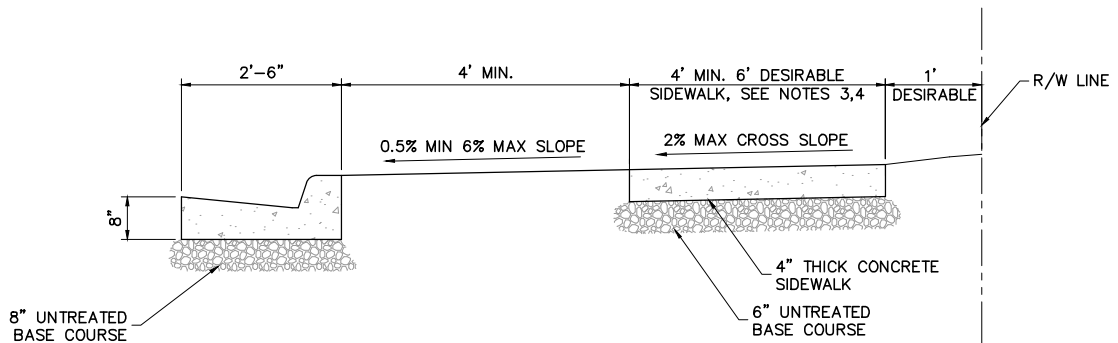

NOTES:

1. INSTALL 8:1 OR FLATTER TAPER WHEN CHANGING THE WIDTH OF SIDEWALK.
2. PROVIDE A 5 FT X 5 FT PASSING SPACE ON PEDESTRIAN ACCESS ROUTES LESS THAN 5 FT WIDE AT INTERVALS OF 200 FT MAXIMUM.
3. SIDEWALK CROSS SLOPE DIMENSIONS SHOWN ARE NOT SUBJECT TO CONVENTIONAL INDUSTRY TOLERANCES. CONSTRUCT SIDEWALKS AND RAMPS SUCH THAT THE MINIMUM AND MAXIMUM VALUES ARE EXCEEDED. WORK THAT EXCEEDS THOSE VALUES WILL NOT BE ACCEPTED.
4. PROVIDE A 5 FT X 5 FT PASSING AREA ON SIDEWALKS OF LESS THAN 5 FT WIDE WHEN THERE IS NOT A HARD SURFACE PASSING AREA OF 5 FT MINIMUM WIDTH IN A 200 FT SEGMENT.
5. A MINIMUM OF 7 FT IS REQUIRED AT BACK OF SIDEWALK AT DRIVEWAY LOCATIONS TO MEET GRADING REQUIREMENTS.

PARK STRIP DETAIL (A)
N.T.S.

SLOPE TABLE			
	ITEM	MAX RUNNING SLOPE *	MAX CROSS SLOPE *
(T)	TURNING SPACE	2%	2% (d)
(R)	RAMP	8.3% (a) 5.1% MIN	2%
(B)	BLENDED TRANSITION	5%	2% (d)
(C)	CLEAR SPACE/GUTTER	5% (b)	2% (d)
(S)	SIDEWALK	-	2%
(F1)	FLARE WITHIN SIDEWALK	10% (c)	-
(F2)	FLARE NOT IN SIDEWALK	25% (c)	-
	CROSSWALK	5%	2% (e) (F)

- * RUNNING SLOPE IS IN THE DIRECTION OF PEDESTRIAN TRAVEL.
- ** CROSS SLOPE IS PERPENDICULAR TO PEDESTRIAN TRAVEL. SEE CLEAR SPACE/GUTTER DETAIL C
- (a) LENGTH OF RUNNING SLOPE FOR RAMPS IS NOT REQUIRED TO EXCEED 15 FT.
- (b) MAINTAIN CONSISTENCY OF CLEAR SPACE RUNNING SLOPE ACROSS ENTIRE CURB CUT. WARP GUTTER PAN TO MEET REQUIRED CLEAR SPACE SLOPE AT CURB CUT.
- (c) MEASURE FLARE SLOPE PARALLEL TO CURB LINE.
- (d) DO NOT EXCEED THE ROADWAY PROFILE GRADE FOR THE CROSS SLOPE AT CROSSWALKS WITHOUT A STOP OR YIELD SIGN AND AT MID-BLOCK CROSSWALKS.
- (e) DO NOT EXCEED 5 PERCENT CROSS SLOPE AT CROSSWALKS AT INTERSECTIONS WITHOUT A STOP OR YIELD SIGN.
- (f) DO NOT EXCEED A CROSS SLOPE EQUAL TO THE STREET OR HIGHWAY GRADE AT MID BLOCK CROSSWALKS.

<p align="center">STATEMENT OF USE</p> <p><small>THIS DOCUMENT AND ANY ILLUSTRATIONS HEREON ARE PROVIDED AS STANDARD CONSTRUCTION DETAILS WITHIN HOOPER CITY. DEVIATION FROM THIS DOCUMENT REQUIRES APPROVAL OF HOOPER CITY. HOOPER CITY CORPORATION CAN NOT BE HELD LIABLE FOR MISUSE OR CHANGES REGARDING THIS DOCUMENT.</small></p> <p align="center">REVISION</p> <table border="1" style="width: 100%; border-collapse: collapse;"> <tr> <td style="width: 5%;">NO.</td> <td style="width: 65%;">DESCRIPTION</td> <td style="width: 10%;">BY</td> <td style="width: 10%;">DATE</td> </tr> <tr> <td>1</td> <td>REV'D PER NEW A.D.A. REQUIREMENTS</td> <td>JDM</td> <td>TLA 3/9/07</td> </tr> <tr> <td>2</td> <td>REV'D DETECTABLE WARNING DETAIL</td> <td>JDM</td> <td>TLA 9/24/07</td> </tr> <tr> <td> </td> <td> </td> <td> </td> <td> </td> </tr> </table>	NO.	DESCRIPTION	BY	DATE	1	REV'D PER NEW A.D.A. REQUIREMENTS	JDM	TLA 3/9/07	2	REV'D DETECTABLE WARNING DETAIL	JDM	TLA 9/24/07					<p>Engineers • Surveyors • Planners</p>	<p>WHEELCHAIR RAMP</p> <p>HOOPER CITY DEVELOPMENT STANDARDS</p>	<p>STANDARD DRAWING NUMBER: 7B</p> <p>CAD DWG: WHEELCHAIR_RAMP</p> <p>PLOT SCALE: 1 = 2</p> <p>DRAWN BY: JDM</p> <p>DESIGN BY: TLA</p> <p>CHECKED BY: TLA</p> <p>ADOPTED DATE: SEP. 2004</p>
NO.	DESCRIPTION	BY	DATE																
1	REV'D PER NEW A.D.A. REQUIREMENTS	JDM	TLA 3/9/07																
2	REV'D DETECTABLE WARNING DETAIL	JDM	TLA 9/24/07																

GENERAL NOTES:

1. DIMENSIONS SHOWN IN THE SLOPE TABLE ARE NOT SUBJECT TO CONVENTIONAL INDUSTRY TOLERANCES. CONSTRUCT SIDEWALKS AND RAMPS SUCH THAT THE MAXIMUM OR MINIMUM VALUES ARE NOT EXCEEDED. WORK THAT EXCEEDS THOSE VALUES WILL NOT BE ACCEPTED.
2. SITE CONDITIONS WILL VARY, CONFIGURATION OF RAMP, BLENDED TRANSITION, TURNING SPACE AND CLEAR SPACE MAY BE CHANGED, BUT THEY MUST MEET DIMENSIONS AND SLOPES SHOWN HERE. THE USE OF ITEMS SUCH AS FLARES AND CURB WALL ARE AT THE DISCRETION OF THE ENGINEER.
3. RAMP GRADE BREAK MUST BE PERPENDICULAR TO THE RUNNING SLOPE.
4. TURNING SPACE WIDTH: USE THE LARGER OF THE CURB CUT WIDTH OR A 4 FT MINIMUM WIDTH X 4 FT MINIMUM DEPTH.
5. TURNING SPACE DEPTH: USE A 4 FT MINIMUM DEPTH WHEN THE TURNING SPACE IS UNCONSTRAINED. USE A 5 FT MINIMUM DEPTH WHEN THE TURNING SPACE IS CONSTRAINED.
6. CONSTRUCT BLENDED TRANSITIONS WITHOUT A TURNING SPACE ONLY WHEN TECHNICAL INFEASIBILITY PREVENTS THE INSTALLATION OF A TURNING SPACE.
7. LOCATE CURB CUT WITHIN CROSSWALK.
8. USE A 4 FT MINIMUM CURB CUT. USE A 8 FT MINIMUM CURB CUT FOR BI-DIRECTIONAL CROSSWALKS.
9. PROVIDE DIRECTIONAL WARNING SURFACE ACCORDING TO MANUFACTURER'S RECOMMENDATIONS FOR FULL WIDTH OF CURB CUT AND 2 FT MINIMUM IN THE DIRECTION OF PEDESTRIAN TRAVEL. SEE DETECTABLE WARNING SURFACE DETAIL B FOR DIMENSIONS.
10. LOCATE DETECTABLE WARNING SURFACE SO THE OUTSIDE CORNER NEAREST THE STREET IS WITHIN 1 INCH OF THE BACK OF CURB.
11. PLACE DETECTABLE WARNING SURFACE PANELS ON A RADIUS IN A STRAIGHT LINE OR ACCORDING TO DETAIL X. TOP CORNERS OF ADJACENT PANELS TO TOUCH, BOTTOM CORNERS OF ADJACENT PANELS TO HAVE A 2 INCH MAXIMUM GAP.
12. GRIND OFF REMAINING PORTION OF ANY CUT DOMES WHEN DETECTABLE WARNING SURFACE IS CUT. SEAL ALL CUT PANEL EDGES TO PREVENT WATER DAMAGE.
13. PROVIDE DETECTABLE WARNING SURFACE COLOR THAT CONTRASTS WITH ADJACENT WALKING SURFACE, GUTTER, STREET, AND PEDESTRIAN ACCESS ROUTE, EITHER LIGHT-ON-DARK OR DARK-ON-LIGHT.
14. CLEAR SPACE SIZE: USE A 4 FT MINIMUM DEPTH AND THE LARGER OF THE CURB CUT WIDTH OR A 4 FT MINIMUM WIDTH.

STATEMENT OF USE

THIS DOCUMENT AND ANY ILLUSTRATIONS HEREON ARE PROVIDED AS STANDARD CONSTRUCTION DETAILS WITHIN HOOPER CITY. DEVIATION FROM THIS DOCUMENT REQUIRES APPROVAL OF HOOPER CITY. HOOPER CITY CORPORATION CAN NOT BE HELD LIABLE FOR MISUSE OR CHANGES REGARDING THIS DOCUMENT.

REVISION

NO.	DESCRIPTION	BY	APR.	DATE
1	REVD PER NEW A.D.A. REQUIREMENTS	JDM	TLA	3/9/04
2	REVD DETECTABLE WARNING DETAIL	JDM	TLA	9/24/04



WHEELCHAIR RAMP

HOOPER CITY
DEVELOPMENT STANDARDS

STANDARD DRAWING NUMBER: **7C**

CAD DWG: WHEELCHAIR_RAMP
PLOT SCALE: 1 = 2
DRAWN BY: JDM
DESIGN BY: TLA
CHECKED BY: TLA
ADOPTED DATE: SEP. 2004

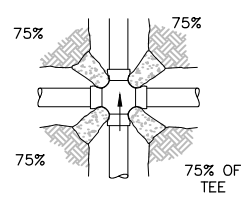
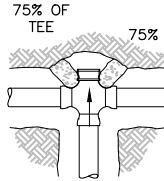
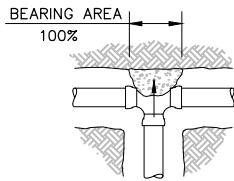

PLANS

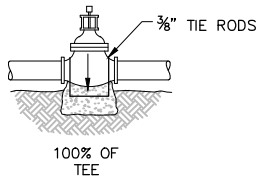
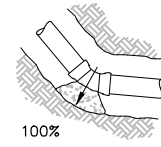
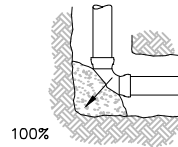
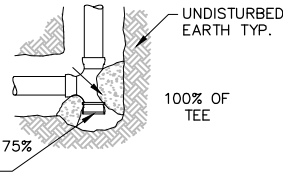
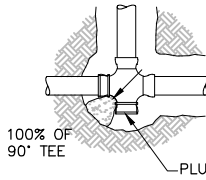

VALVE

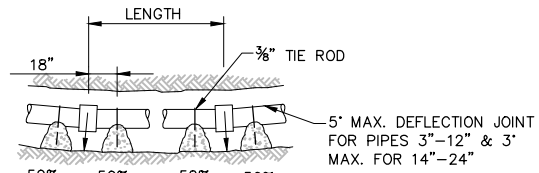

CURVE THRUST BLOCKING

ALL MJ AND FLANGED FITTINGS TO BE WRAPPED WITH POLYETHYLENE WRAP PRIOR TO POURING THRUST BLOCK.

DETAIL NOTES:

1. FIGURE (100%) AT THRUST BLOCK INDICATES PER CENT OF TOTAL THRUST TO BE APPLIED FOR BEARING AREA.
2. ARROW (→) INDICATES THRUST DIRECTION.
3. CONCRETE FOR THRUST BLOCKS TO BE 2000 P.S.I.

EXAMPLE:

8" 90° ELBOW, PRESSURE=200 LB. / SQ. IN.
 FROM TABLE: THRUST = 94 X 200 = 18800 LB.
 ASSUME BEARING STRENGTH OF SOIL = 2000 LB. / SQ. FT.
 18800 ÷ 2000 = 9.4 SQ. FT. = AREA OF BEARING REQUIRED FOR THRUST BLOCK.

PIPE SIZE	SIDE THRUST PER 1 PSI			
	DEAD END OR TEE	90° ELBOW	45° ELBOW	22½° ELBOW
4	19	27	15	7
6	39	55	30	15
8	67	94	51	26
10	109	154	84	43
12	155	218	119	61
14	210	296	161	82
16	272	383	209	106
18	351	494	269	137
20	434	611	333	169
24	623	878	478	244
30	990	1400	757	386
36	1425	2015	1091	556

TABLE NOTES:

1. IN USING THE ABOVE TABLES, USE THE MAXIMUM INTERNAL PRESSURE ANTICIPATED (I.E. HYDROSTATIC TEST PRESSURE, POSSIBLE SURGE PRESSURE DUE TO PUMP SHUT-OFF, ETC.)
2. SEE SOILS REPORT FOR BEARING STRENGTH OF SOIL IN THE ABSENCE OF A SOILS REPORT, AND AVERAGE SOIL (SPADABLE MEDIUM CLAY) CAN BE ASSUMED TO HAVE A BEARING STRENGTH OF 2000 P.S.F.

THRUST BLOCK DETAILS

STATEMENT OF USE			
THIS DOCUMENT AND ANY ILLUSTRATIONS HEREON ARE PROVIDED AS STANDARD CONSTRUCTION DETAILS WITHIN HOOPER CITY. DEVIATION FROM THIS DOCUMENT REQUIRES APPROVAL OF HOOPER CITY. HOOPER CITY CORPORATION CAN NOT BE HELD LIABLE FOR MISUSE OR CHANGES REGARDING THIS DOCUMENT.			
REVISION			
NO.	DESCRIPTION	BY	APR. DATE



THRUST BLOCK DETAILS

HOOPER CITY
DEVELOPMENT STANDARDS

STANDARD DRAWING NUMBER: **8**

CAD DWG: THRUST_BLOCK
 PLOT SCALE: 1 = 96
 DRAWN BY: JDM
 DESIGN BY: TLA
 CHECKED BY: TLA
 ADOPTED DATE: NOV 2003

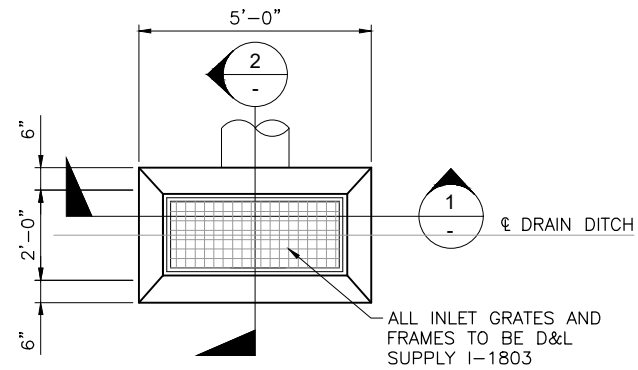

PLAN @ SINGLE CATCH BASIN
SCALE: N.T.S.

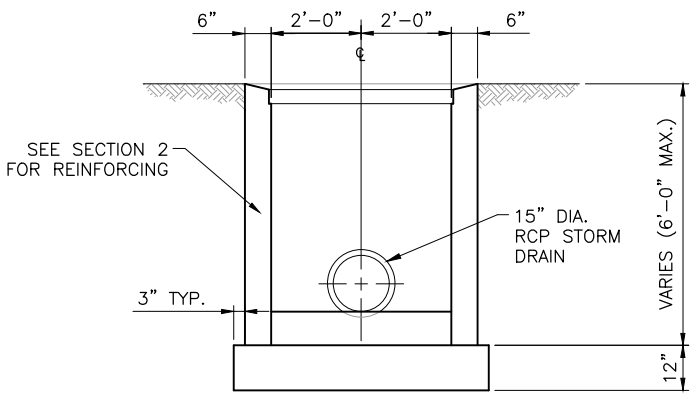

SECTION 1
SCALE: N.T.S.

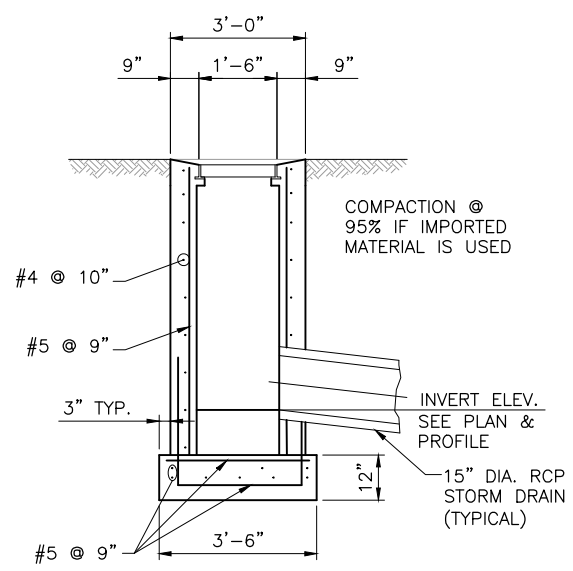

SECTION 2
SCALE: N.T.S.

GENERAL NOTES:

1. ALL STRUCTURAL CONCRETE SHALL DEVELOP A MINIMUM COMPRESSIVE STRENGTH OF 4,000 PSI IN 28 DAYS.
2. REINFORCEMENT STEEL SHALL BE DEFORMED BARS CONFORMING IN QUALITY TO THE REQUIREMENTS OF ASTM DESIGNATION A-615, GRADE 60, INCLUDING SUPPLEMENTARY REQUIREMENTS (S1).
3. ALL DETAILING, FABRICATION AND PLACING OF REINFORCING BARS SHALL BE IN ACCORDANCE WITH THE "MANUAL OF STANDARD PRACTICE FOR DETAILING REINFORCED CONCRETE STRUCTURES" ACI-315, LATEST EDITION.
4. TOLERANCES IN PLACING REINFORCEMENT SHALL BE:
 - ± 3/8 INCH FOR MEMBERS WITH D < 8 INCHES
 - ± 1/2 INCH FOR MEMBERS WITH D ≥ 8 INCHES
5. DOWELS, PIPES, WATERSTOPS AND OTHER INSTALLED MATERIALS AND ACCESSORIES SHALL BE HELD SECURELY IN POSITION WHILE CONCRETE IS BEING PLACED.
6. UNLESS OTHERWISE SHOWN, ASIDE FROM NORMAL ACCESSORIES USED TO HOLD REINFORCING BARS FIRMLY IN POSITION, THE FOLLOWING SHALL BE ADDED:
 - A) IN SLABS #5 RISER BARS AT 36 INCHES O.C. MAXIMUM TO SUPPORT TOP REINFORCING BARS.
 - B) IN WALLS WITH 2 CURTAINS #3 U OR Z SHAPE SPACES AT 6 FEET O.C. EACH WAY.
7. METAL CLIPS OR SUPPORTS SHALL NOT BE PLACED IN CONTACT WITH THE FORMS OR THE SUBGRADE. CONCRETE BLOCKS (OR DOBBIES) SUPPORTING BARS ON SUBGRADE SHALL BE IN SUFFICIENT NUMBERS TO SUPPORT THE BARS WITHOUT SETTLEMENT, BUT IN NO CASE SHALL SUCH SUPPORT BE CONTINUOUS.
8. DOWELS SHALL BE WIRED OR OTHERWISE HELD IN POSITION. THEY SHALL NOT BE SHOVED INTO FRESHLY PLACED CONCRETE.
9. REINFORCED BARS AND ACCESSORIES SHALL NOT BE IN CONTACT WITH ANY PIPE, PIPE FLANGE OR METAL PARTS EMBEDDED IN CONCRETE, A MINIMUM OF 2 INCHES CLEARANCE SHALL BE PROVIDED AT ALL TIMES.
10. STRUCTURES SHALL BE BACKFILLED WITH GRANULAR SOIL.
11. ALL CONSTRUCTION JOINTS SHALL BE ROUGHED AND CLEANED AND FREE OF LAITANCE.
12. STRUCTURES HAVE BEEN DESIGNED FOR THE FOLLOWING; IF CONDITIONS ARE EXCEEDED THE ENGINEER SHALL BE NOTIFIED.
 - A) AASHTO HS-20 TRUCK LOAD
 - B) 1'-6" MAX. SOIL ABOVE THE ROOF OF THE STRUCTURE
 - C) GROUND WATER TO TOP OF STRUCTURE
 - D) "AT-REST" LATERAL SOIL PRESSURE OF 60 PCF FOR DRY SOIL CONDITIONS AND 92.4 PCF WHEN GROUND WATER IS PRESENT

STATEMENT OF USE
THIS DOCUMENT AND ANY ILLUSTRATIONS HEREON ARE PROVIDED AS STANDARD CONSTRUCTION DETAILS WITHIN HOOPER CITY. DEVIATION FROM THIS DOCUMENT REQUIRES APPROVAL OF HOOPER CITY. HOOPER CITY CORPORATION CAN NOT BE HELD LIABLE FOR MISUSE OR CHANGES REGARDING THIS DOCUMENT.

NO.	REVISION	BY	APR.	DATE



**STANDARD SINGLE CATCH BASIN
(NO CURB & GUTTER)**

**HOOPER CITY
DEVELOPMENT STANDARDS**

STANDARD DRAWING NUMBER: 9

CAD DWG: CATCH_BASIN_STD
PLOT SCALE: 1 = 1
DRAWN BY: JDM
DESIGN BY: TLA
CHECKED BY: TLA
ADOPTED DATE: DEC 2007

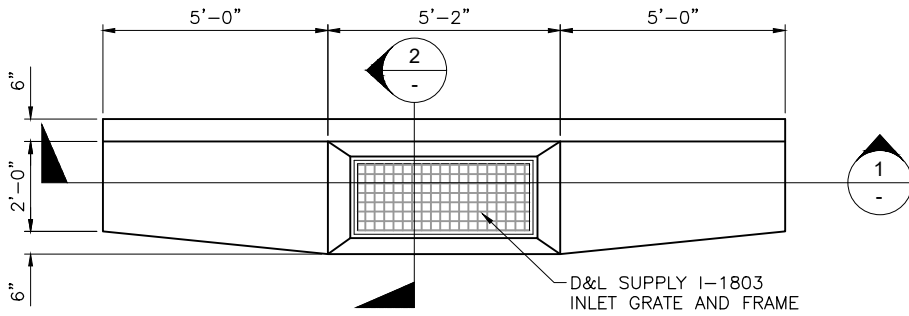

PLAN @ SINGLE CATCH BASIN

SCALE: N.T.S.

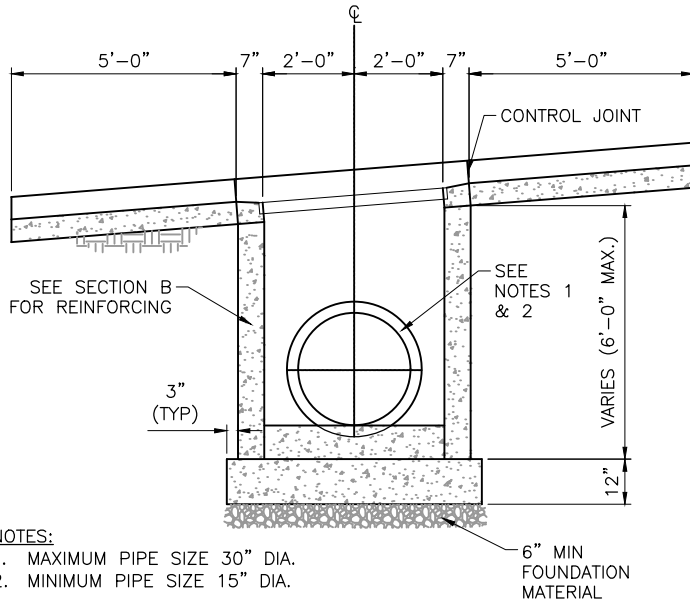

SECTION 1

SCALE: N.T.S.

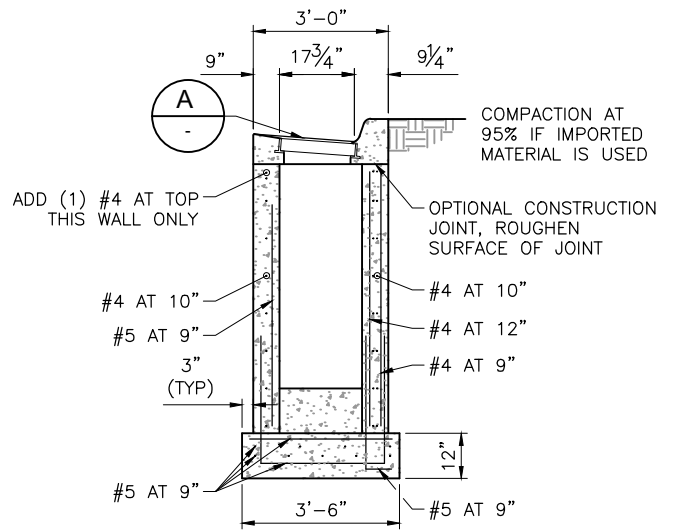

SECTION 2

SCALE: N.T.S.



NOTES:

1. MAXIMUM PIPE SIZE 30" DIA.
2. MINIMUM PIPE SIZE 15" DIA.

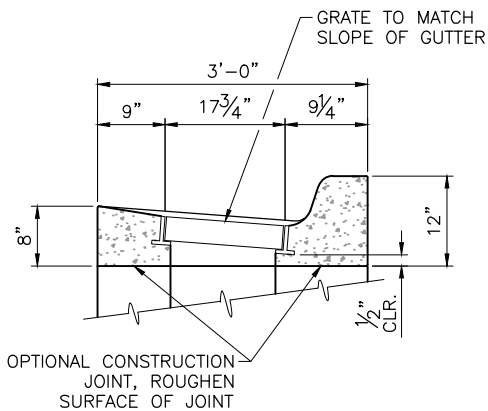

DETAIL A

SCALE: N.T.S.



STATEMENT OF USE

THIS DOCUMENT AND ANY ILLUSTRATIONS HEREON ARE PROVIDED AS STANDARD CONSTRUCTION DETAILS WITHIN HOOPER CITY. DEVIATION FROM THIS DOCUMENT REQUIRES APPROVAL OF HOOPER CITY. HOOPER CITY CORPORATION CAN NOT BE HELD LIABLE FOR MISUSE OR CHANGES REGARDING THIS DOCUMENT.

REVISION

NO.	DESCRIPTION	BY	APR.	DATE



**SINGLE CATCH BASIN
(WITH CURB & GUTTER)**

HOOPER CITY
DEVELOPMENT STANDARDS

STANDARD DRAWING NUMBER: **10**

CAD DWG: CATCH_BASIN_A11
PLOT SCALE: 1 = 48
DRAWN BY: JDM
DESIGN BY: TLA
CHECKED BY: TLA
ADOPTED DATE: NOV 2003

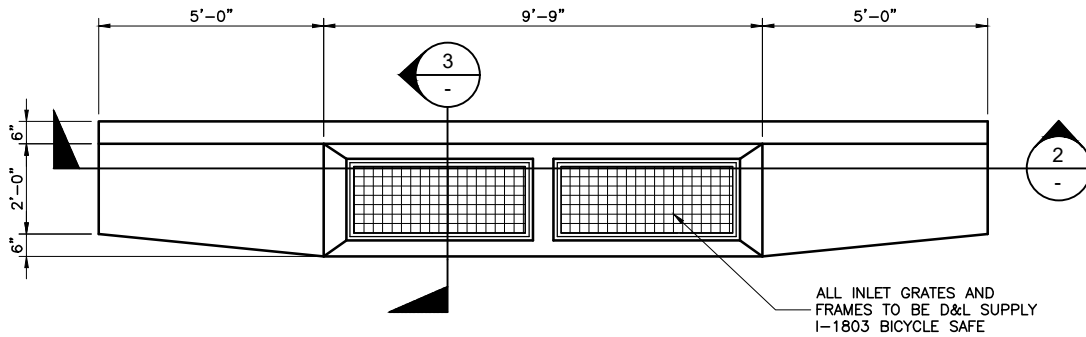

WHERE DIRECTED
BY CITY ENGINEER

PLAN @ DOUBLE CATCH BASIN
SCALE: N.T.S.

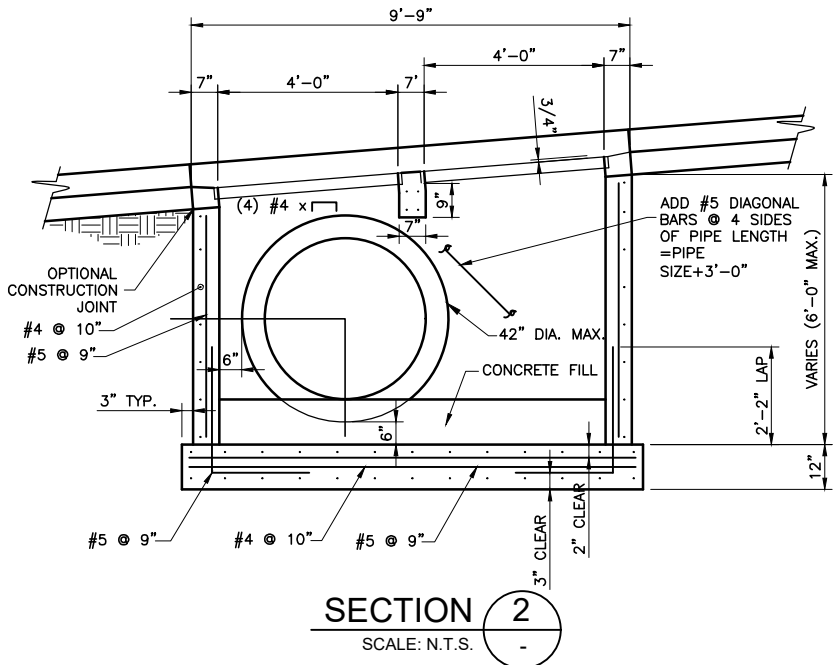

SECTION 2
SCALE: N.T.S.

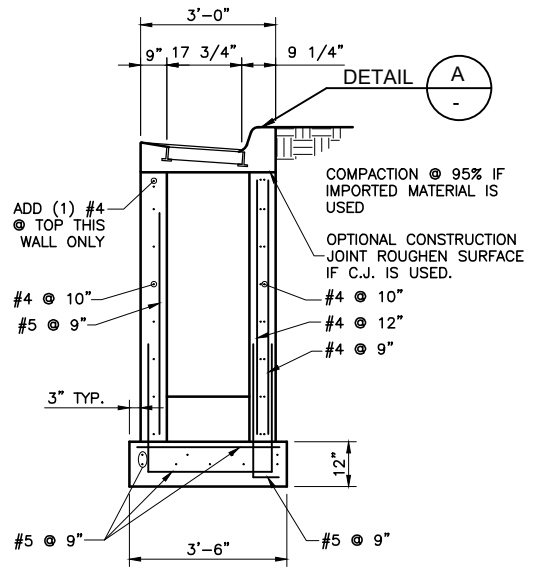

SECTION 3
SCALE: N.T.S.

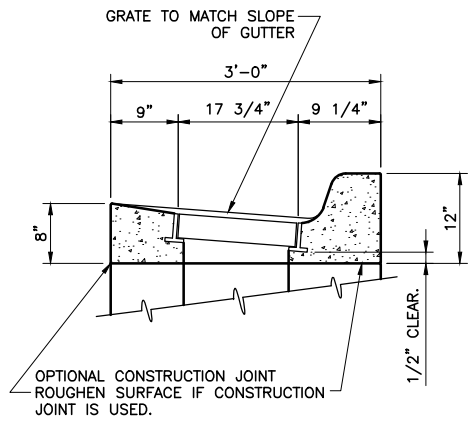

CURB & GUTTER
DETAIL A
SCALE: N.T.S.

STATEMENT OF USE
THIS DOCUMENT AND ANY ILLUSTRATIONS HEREON ARE PROVIDED AS STANDARD CONSTRUCTION DETAILS WITHIN HOOPER CITY. DEVIATION FROM THIS DOCUMENT REQUIRES APPROVAL OF HOOPER CITY. HOOPER CITY CORPORATION CAN NOT BE HELD LIABLE FOR MISUSE OR CHANGES REGARDING THIS DOCUMENT.

NO.	REVISION	DESCRIPTION	BY	APR.	DATE



DOUBLE CATCH BASIN

HOOPER CITY
DEVELOPMENT STANDARDS

STANDARD DRAWING NUMBER:	11
CAD DWG: CATCH_BASIN_AL 2	
PLOT SCALE:	1 = 96
DRAWN BY:	JDM
DESIGN BY:	TLA
CHECKED BY:	TLA
ADOPTED DATE:	AUG 2001

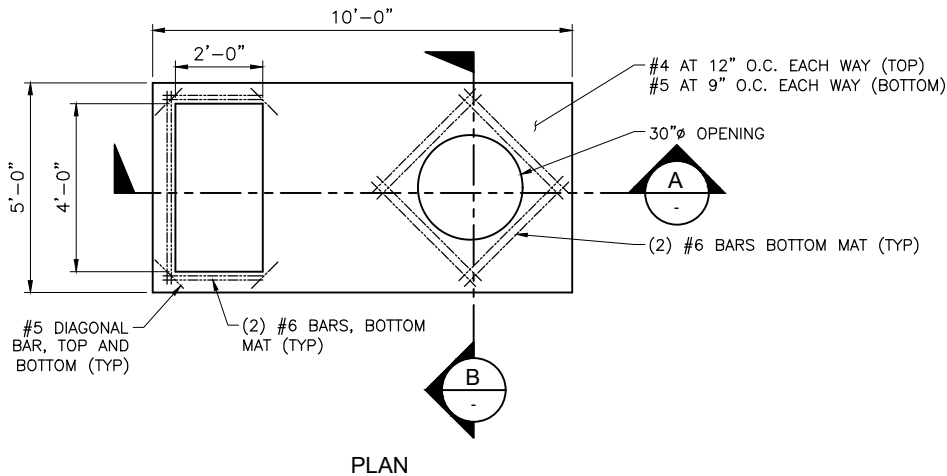

PLAN

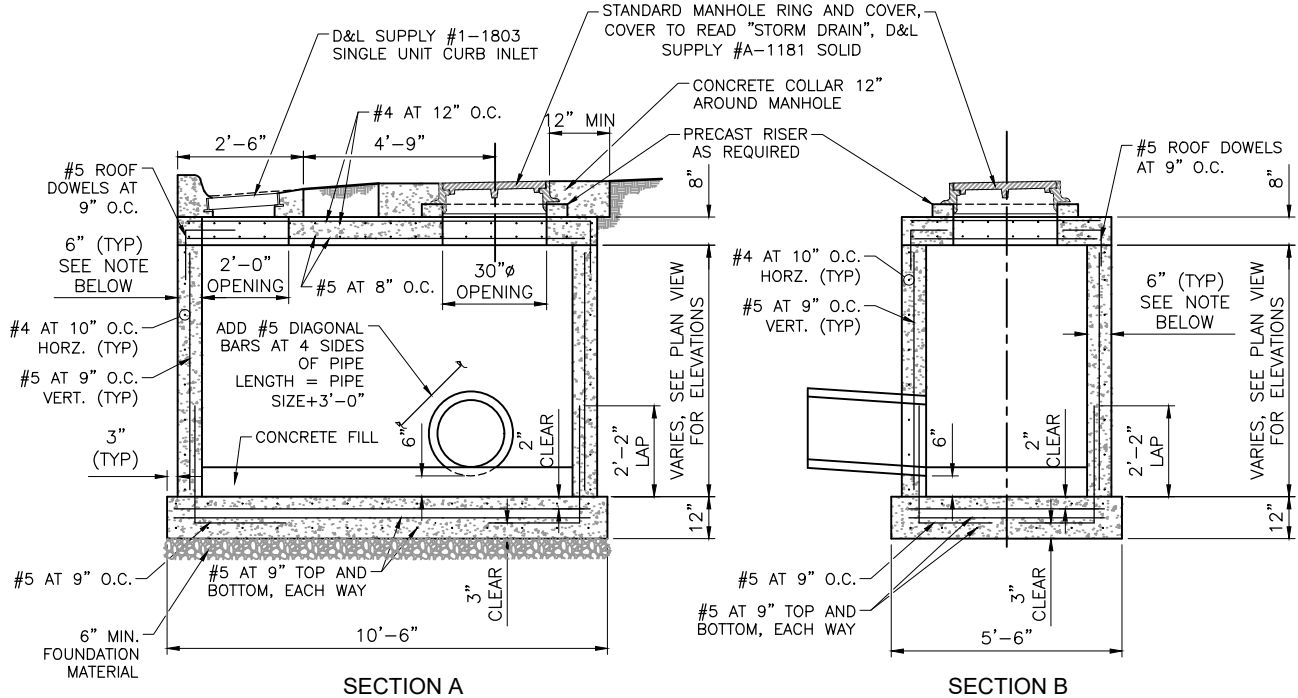

SECTION A

SECTION B

NOTE:
 USE 6" THICK WALLS FOR WALL HEIGHT UP TO 5'-0". FOR WALL HEIGHT GREATER THAN 5'-0", USE 8" THICK WALLS.

1 COMBINATION INLET/CLEANOUT DETAIL
 SCALE: NOT TO SCALE

STATEMENT OF USE
 THIS DOCUMENT AND ANY ILLUSTRATIONS HEREON ARE PROVIDED AS STANDARD CONSTRUCTION DETAILS WITHIN HOOPER CITY. DEVIATION FROM THIS DOCUMENT REQUIRES APPROVAL OF HOOPER CITY. HOOPER CITY CORPORATION CAN NOT BE HELD LIABLE FOR MISUSE OR CHANGES REGARDING THIS DOCUMENT.

NO.	REVISION	DESCRIPTION	BY	APR.	DATE



STANDARD STORM DRAIN COMBO BOX

HOOPER CITY
 DEVELOPMENT STANDARDS

STANDARD DRAWING NUMBER:	12
CAD DWG: SD_CLEANOUT	
PLOT SCALE: 1 = 96	
DRAWN BY: JDM	
DESIGN BY: TLA	
CHECKED BY: TLA	
ADOPTED DATE: NOV 2003	

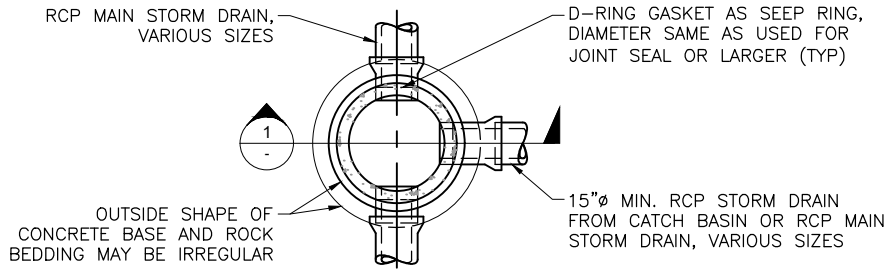

MANHOLE PLAN VIEW BELOW CONE

SCALE: N.T.S.

NOTES:

1. MANHOLE WALL AND CONE SECTION SHALL CONFORM TO ASTM C-478.
2. LIFT HOLE SHALL BE FILLED WITH GROUT.
3. IF MANHOLES ARE TOO SHALLOW FOR CONE SECTION, USE FLAT CONCRETE LID INSTEAD.
4. STEPS @ 12" O.C. ARE REQUIRED IN MANHOLES GREATER THAN 54" DEEP. STEPS SHALL BE NON-CORROSIVE POLY PROPYLENE COATED STEEL AND CONFORM TO ASTM C-478.
5. MANHOLE CONE SHALL BE ECCENTRIC.
6. THE MAXIMUM SIZE PIPE THAT CAN BE USED IN A 48-INCH MANHOLE IS 21-INCH RCP.

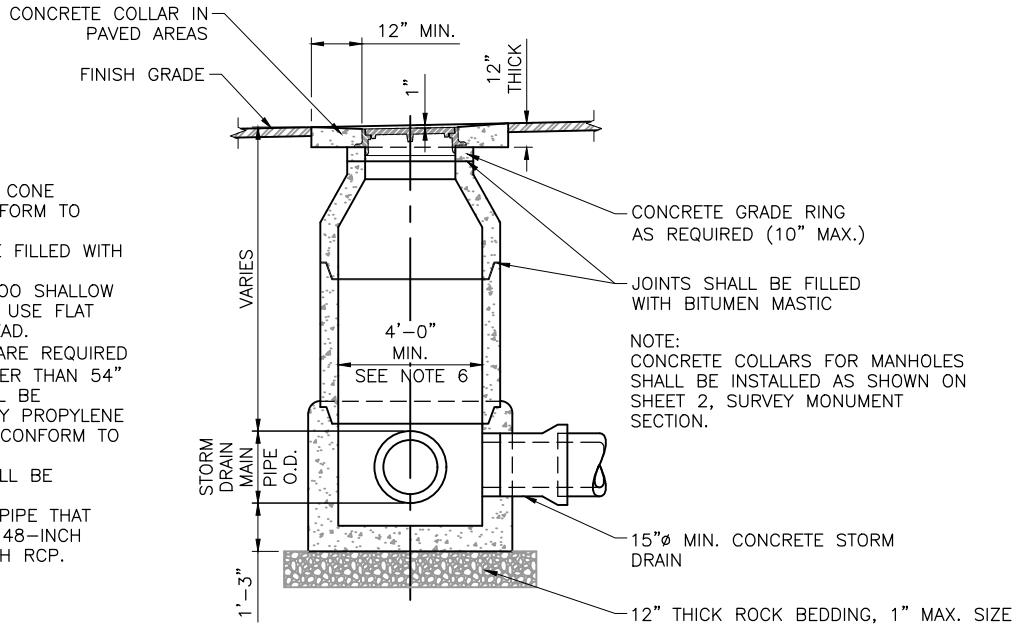

TYPICAL MANHOLE SECTION

SCALE: N.T.S.



NOTE:
CONCRETE COLLARS FOR MANHOLES SHALL BE INSTALLED AS SHOWN ON SHEET 2, SURVEY MONUMENT SECTION.

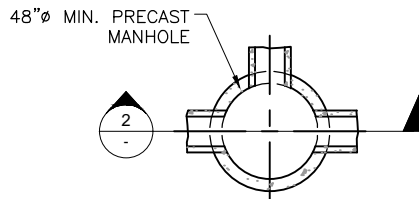

FLAT LID STORM DRAIN MANHOLE PLAN

SCALE: N.T.S.

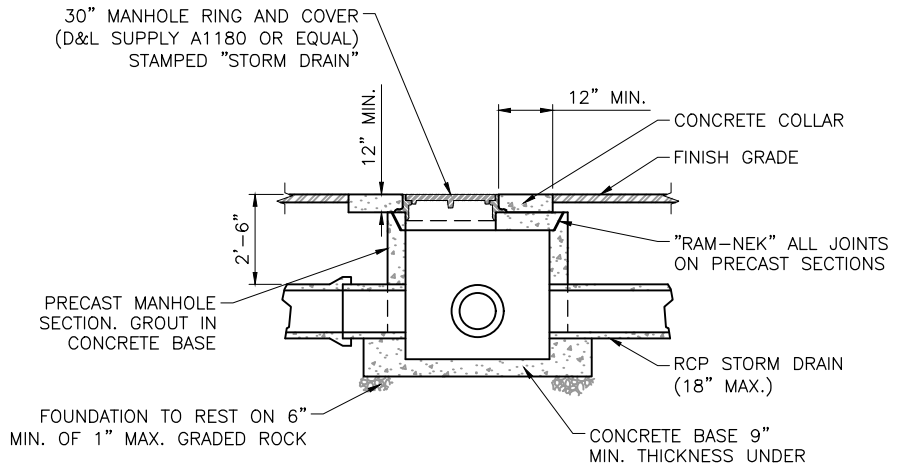

SECTION 2

SCALE: N.T.S.



STATEMENT OF USE

THIS DOCUMENT AND ANY ILLUSTRATIONS HEREON ARE PROVIDED AS STANDARD CONSTRUCTION DETAILS WITHIN HOOPER CITY. DEVIATION FROM THIS DOCUMENT REQUIRES APPROVAL OF HOOPER CITY. HOOPER CITY CORPORATION CAN NOT BE HELD LIABLE FOR MISUSE OR CHANGES REGARDING THIS DOCUMENT.

REVISION

NO.	DESCRIPTION	BY	APR.	DATE



STANDARD STORM DRAIN MANHOLES

HOOPER CITY
DEVELOPMENT STANDARDS

STANDARD DRAWING NUMBER: **13**

CAD DWG: SDMH
PLOT SCALE: 1 = 48
DRAWN BY: JDM
DESIGN BY: TLA
CHECKED BY: TLA
ADOPTED DATE: NOV 2003

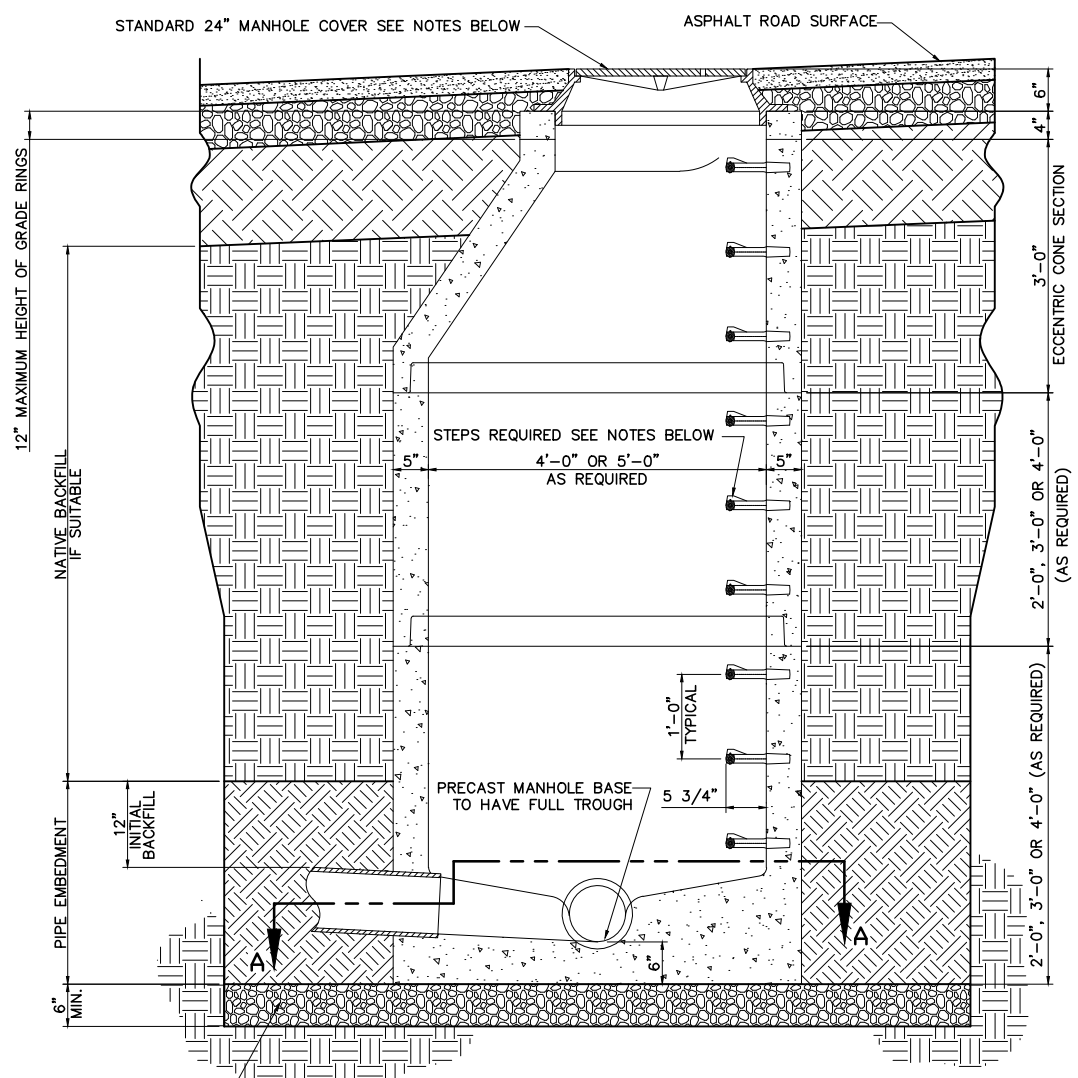

ELEVATION SECTION

3/4" GRAVEL FOUNDATION OUTSIDE SHAPE MAY BE IRREGULAR. MAXIMUM THICKNESS WILL DEPEND ON SPECIFIC SITE CONDITIONS.

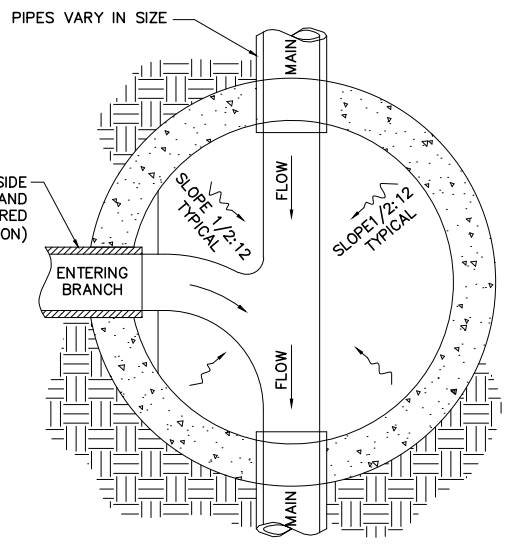

SECTION A-A

- NOTES:
1. MANHOLE COVER TO CONTAIN ONE PICK HOLE. SEE SPECIFICATION DIVISION 5 FOR COVER LABEL. D&L SUPPLY P/N A-1181 (OR EQUAL).
 2. STEP SHALL BE MADE OF COPOLYMER POLYPROPYLENE CONFORMING TO ASTM D-4101. REINFORCING STEEL TO BE DEFORMED 1/2" DIAMETER GRADE 60 ROD.
 3. FLAT LIDS MAY BE USED IN LIEU OF ECCENTRIC CONES WHERE NECESSARY. FLAT LIDS SHALL BE OF ECCENTRIC DESIGN AND MEET H20 LIVE LOADING. NO FLAT RING AND COVERS WILL BE ALLOWED UNLESS APPROVED BY PUBLIC WORKS.
 4. USE FERNCO COUPLING TO TRANSITION TO CONCRETE OR PVC PIPE AS APPROPRIATE.

STATEMENT OF USE

THIS DOCUMENT AND ANY ILLUSTRATIONS HEREON ARE PROVIDED AS STANDARD CONSTRUCTION DETAILS WITHIN HOOPER CITY. DEVIATION FROM THIS DOCUMENT REQUIRES APPROVAL OF HOOPER CITY. HOOPER CITY CORPORATION CAN NOT BE HELD LIABLE FOR MISUSE OR CHANGES REGARDING THIS DOCUMENT.

NO.	REVISION	BY	APR.	DATE



TYPICAL SEWER MANHOLE

HOOPER CITY
DEVELOPMENT STANDARDS

STANDARD DRAWING NUMBER: **14A**

CAD DWG: SEWER_MH
 PLOT SCALE: 1 = 1
 DRAWN BY: JDM
 DESIGN BY: TLA
 CHECKED BY: TLA
 ADOPTED DATE: NOV 2003

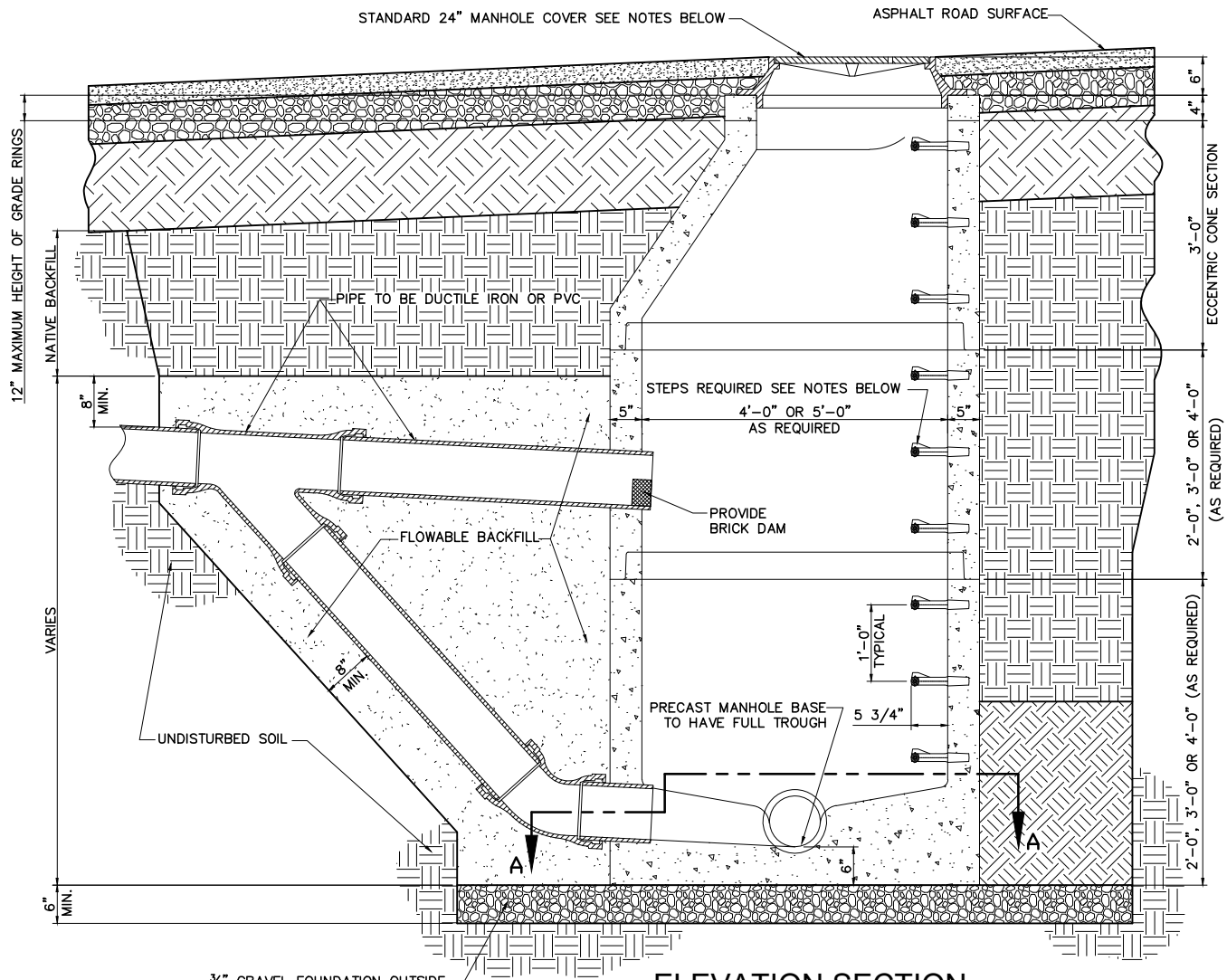

ELEVATION SECTION

3/4" GRAVEL FOUNDATION OUTSIDE SHAPE MAY BE IRREGULAR. MAXIMUM THICKNESS WILL DEPEND ON SPECIFIC SITE CONDITIONS.

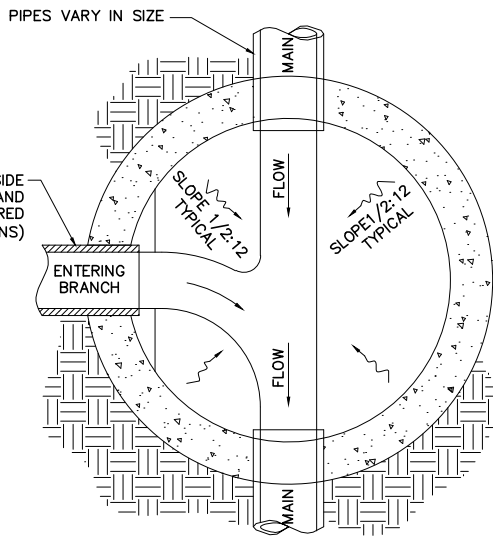

SECTION A-A

NOTES:

1. MANHOLE COVER TO CONTAIN ONE PICK HOLE. SEE SPECIFICATION DIVISION 5 FOR COVER LABEL. D&L SUPPLY P/N A-1181 (OR EQUAL).
2. STEP SHALL BE MADE OF COPOLYMER POLYPROPYLENE CONFORMING TO ASTM D-4101. REINFORCING STEEL TO BE DEFORMED 1/2" DIAMETER GRADE 60 ROD.
3. FLAT LIDS MAY BE USED IN LIEU OF ECCENTRIC CONES WHERE NECESSARY. FLAT LIDS SHALL BE OF ECCENTRIC DESIGN AND MEET H20 LIVE LOADING. NO FLAT RING AND COVERS WILL BE ALLOWED UNLESS APPROVED BY PUBLIC WORKS.
4. USE FERNCO COUPLING TO TRANSITION TO CONCRETE OR PVC PIPE AS APPROPRIATE.

STATEMENT OF USE

THIS DOCUMENT AND ANY ILLUSTRATIONS HEREON ARE PROVIDED AS STANDARD CONSTRUCTION DETAILS WITHIN HOOPER CITY. DEVIATION FROM THIS DOCUMENT REQUIRES APPROVAL OF HOOPER CITY. HOOPER CITY CORPORATION CAN NOT BE HELD LIABLE FOR MISUSE OR CHANGES REGARDING THIS DOCUMENT.

REVISION

NO.	DESCRIPTION	BY	APR.	DATE



TYPICAL DROP MANHOLE

HOOPER CITY
DEVELOPMENT STANDARDS

STANDARD DRAWING NUMBER: **14B**

CAD DWG: DROP_MH
PLOT SCALE: 1 = 1
DRAWN BY: JDM
DESIGN BY: TLA
CHECKED BY: TLA
ADOPTED DATE: NOV 2003

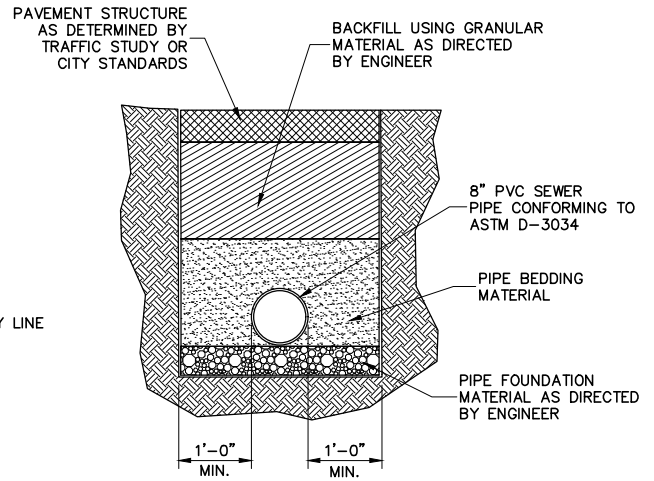
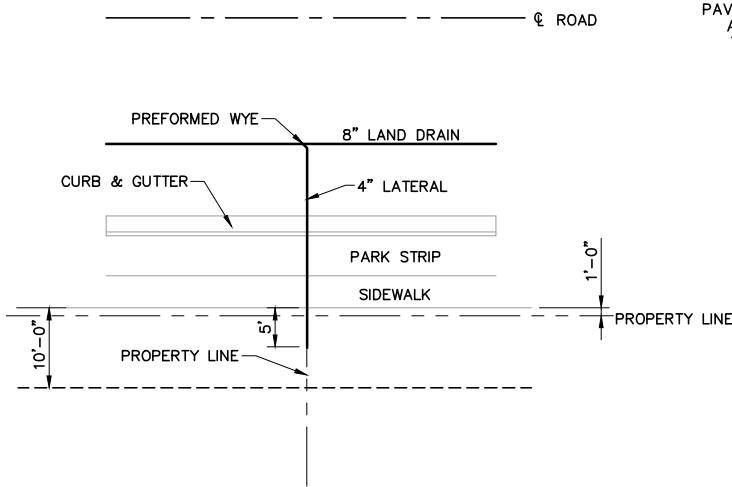

- NOTES:
1. ALL CONNECTIONS SHALL BE MADE USING PREFORMED FITTINGS CONFORMING TO ASTM D-3034.
 2. CONTRACTOR SHALL PROVIDE A CLEANOUT WITHIN 5'-0" OF HOUSE.
 3. LAND DRAIN LATERALS TO BE WHITE PVC TO DIFFERENTIATE FROM SANITARY SEWER LATERALS. MARK END WITH 2X4, PAINTED GREEN.
 4. LAND DRAIN LATERAL MUST FLOW BY GRAVITY TO THE MAIN.

TIGHT JOINT LAND DRAIN LATERAL DETAIL

SCALE: N.T.S.

BACKFILL USING GRANULAR FILTER MATERIAL TO MAXIMUM GROUNDWATER ELEVATION AS DIRECTED BY THE ENGINEER.

- NOTES:
1. DEWATERING SHALL NOT ALLOW PIPING OF FINES.

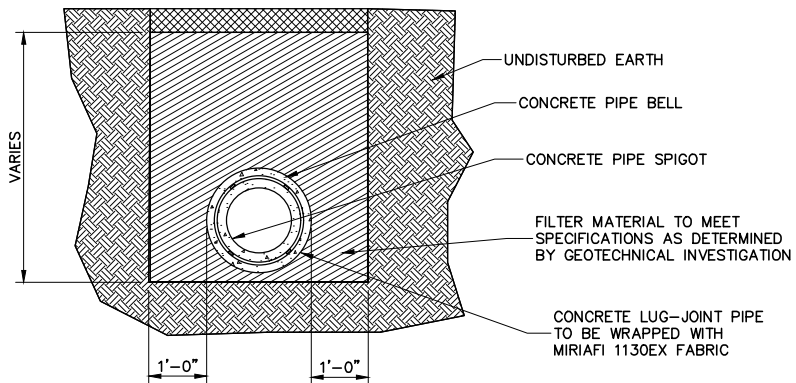

OPEN JOINT LAND DRAIN LATERAL DETAIL

SCALE: N.T.S. ONLY WHEN APPROVED BY CITY PUBLIC WORKS

STATEMENT OF USE

THIS DOCUMENT AND ANY ILLUSTRATIONS HEREON ARE PROVIDED AS STANDARD CONSTRUCTION DETAILS WITHIN HOOPER CITY. DEVIATION FROM THIS DOCUMENT REQUIRES APPROVAL OF HOOPER CITY. HOOPER CITY CORPORATION CAN NOT BE HELD LIABLE FOR MISUSE OR CHANGES REGARDING THIS DOCUMENT.

REVISION

NO.	DESCRIPTION	BY	APR.	DATE
▲				
▲				
▲				



LAND DRAIN DETAILS

HOOPER CITY
DEVELOPMENT STANDARDS

STANDARD DRAWING NUMBER: **15A**

CAD DWG: LAND_DRAIN
PLOT SCALE: 1 = 96
DRAWN BY: JDM
DESIGN BY: TLA
CHECKED BY: TLA
ADOPTED DATE: NOV 2003

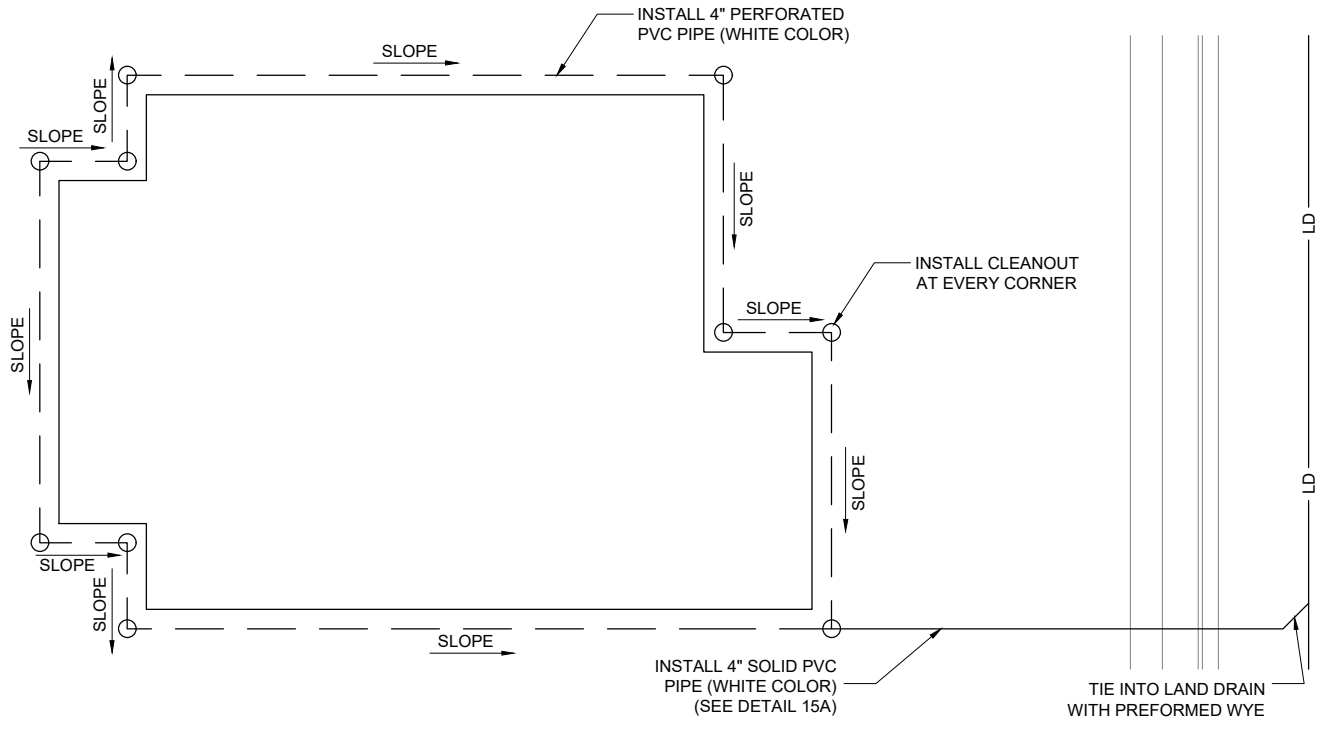

PLAN

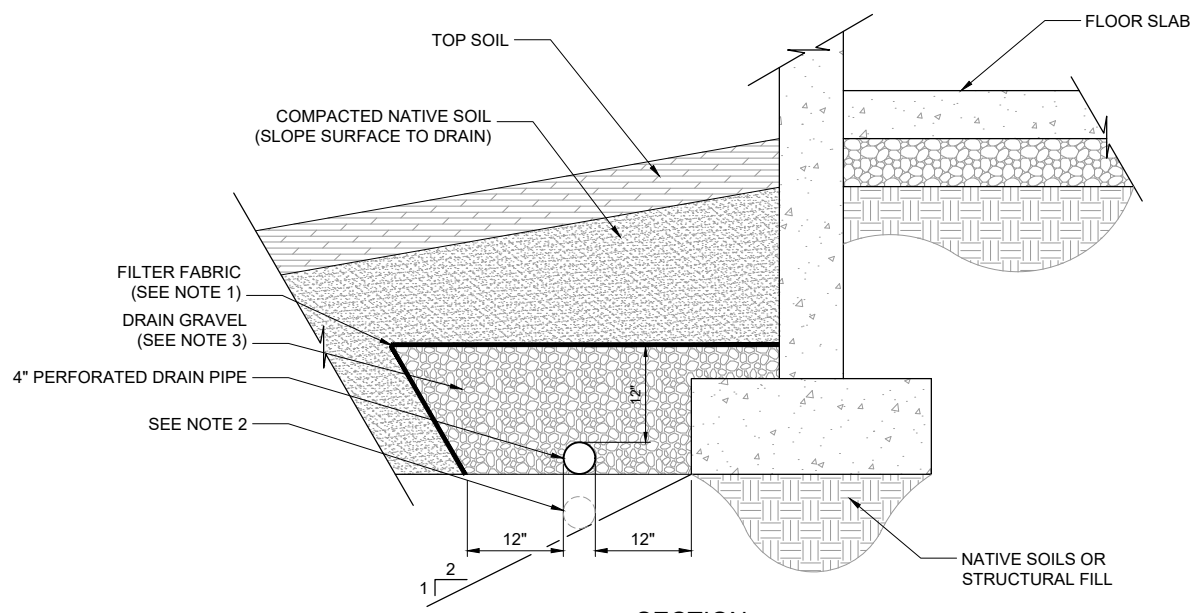

SECTION

NOTES:

1. FILTER FABRIC IS NON-WOVEN GEOTEXTILE (MIRAFI 140N, OR EQUIVALENT).
2. LAY PERFORATED DRAIN PIPE ON MINIMUM 0.5% GRADIENT, WIDENING EXCAVATION AS REQUIRED. MAINTAIN PIPE ABOVE 2:1 SLOPE AS SHOWN.
3. DRAIN GRAVEL TO BE CLEAN, WASHED, 3/4" TO 1 1/2" GRAVEL.
4. PROVIDE SOLID DRAIN PIPE BEYOND BUILDING PERIMETER TO TIE TO LAND DRAIN SYSTEM.
5. LAND DRAIN LATERALS SHALL BE "WHITE" PVC PIPE.

FOOTING DRAIN
NOT TO SCALE

STATEMENT OF USE
THIS DOCUMENT AND ANY ILLUSTRATIONS HEREON ARE PROVIDED AS STANDARD CONSTRUCTION DETAILS WITHIN HOOPER CITY. DEVIATION FROM THIS DOCUMENT REQUIRES APPROVAL OF HOOPER CITY. HOOPER CITY CORPORATION CAN NOT BE HELD LIABLE FOR MISUSE OR CHANGES REGARDING THIS DOCUMENT.

REVISION			
NO.	DESCRIPTION	BY	DATE



FOOTING DRAIN

HOOPER CITY
DEVELOPMENT STANDARDS

STANDARD DRAWING NUMBER:	15B
CAD DWG: FOOTING_DRAIN	
PLOT SCALE:	1 = 96
DRAWN BY:	JDM
DESIGN BY:	TLA
CHECKED BY:	TLA
ADOPTED DATE:	NOV 2003

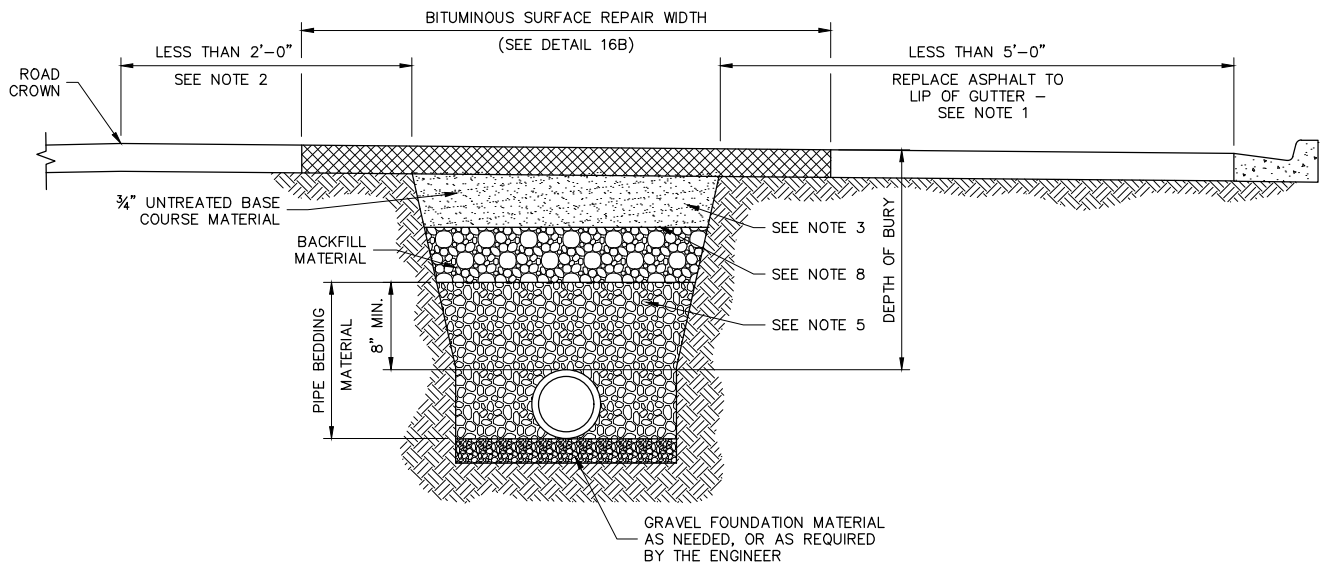

NOTES:

1. WHERE NO CURB & GUTTER EXISTS AND THE EDGE OF THE TRENCH IS LESS THAN 5'-0" FROM THE EXISTING EDGE OF ASPHALT, REPLACE ENTIRE SECTION OF PAVEMENT FROM EDGE OF TRENCH TO EXISTING EDGE OF ASPHALT.
2. WHERE THE EDGE OF THE TRENCH IS LESS THAN 2'-0" FROM THE EXISTING CROWN OF THE ROAD, SAW CUT AT EXISTING CROWN AND REPLACE AFFECTED LANE FULL DEPTH.
3. SAW CUT BITUMINOUS ASPHALT SURFACE WIDER THAN TRENCH ON EACH SIDE FOR FINAL TRENCH REPAIR WHERE BITUMINOUS SURFACE EXISTS. (DETAIL 16B).
4. BITUMINOUS SURFACE IS TO BE 6" OR TO MATCH EXISTING THICKNESS, WHICHEVER IS GREATER FOR STATE ROADS & 3" OR MATCH EXISTING THICKNESS, WHICHEVER IS GREATER FOR OTHER ROADS.
5. FOR TRENCH REPAIR, 3/4" UNTREATED BASE COURSE MATERIAL IS TO BE 12" OR TO MATCH EXISTING THICKNESS, WHICHEVER IS GREATER. FOR NEW ROAD CONSTRUCTION, 3/4" UNTREATED BASE COURSE MATERIAL IS TO BE 10" MIN. OR AS DIRECTED BY THE ENGINEER. BASE COURSE TO BE COMPACTED TO 96% ASTM D-1557.
6. SLOPE TRENCH SIDES TO MEET OSHA SAFETY REGULATIONS. (LATEST REV.)
7. BACKFILL TO BE COMPACTED TO 96% ASTM D-1557.
8. USE GEOTEXTILE FABRIC TO MATCH EXISTING OR WHERE REQUIRED.

BITUMINOUS SURFACE REPAIR* & TYPICAL TRENCH SECTION

SCALE: N.T.S.

* NOTE: EXISTING BITUMINOUS SURFACE COURSE NEWER THAN ROAD CUT MORATORIUM PLUS FIVE YEARS

STATEMENT OF USE			
THIS DOCUMENT AND ANY ILLUSTRATIONS HEREON ARE PROVIDED AS STANDARD CONSTRUCTION DETAILS WITHIN HOOPER CITY. DEVIATION FROM THIS DOCUMENT REQUIRES APPROVAL OF HOOPER CITY. HOOPER CITY CORPORATION CAN NOT BE HELD LIABLE FOR MISUSE OR CHANGES REGARDING THIS DOCUMENT.			
REVISION			
NO.	DESCRIPTION	BY	APR. DATE
▲			
▲			
▲			



BITUMINOUS SURFACE REPAIR & TYPICAL TRENCH SECTION

HOOPER CITY
DEVELOPMENT STANDARDS

STANDARD DRAWING NUMBER:	16A
CAD DWG:	TRENCH_SEC
PLOT SCALE:	1 = 96
DRAWN BY:	JDM
DESIGN BY:	TLA
CHECKED BY:	TLA
ADOPTED DATE:	NOV 2010

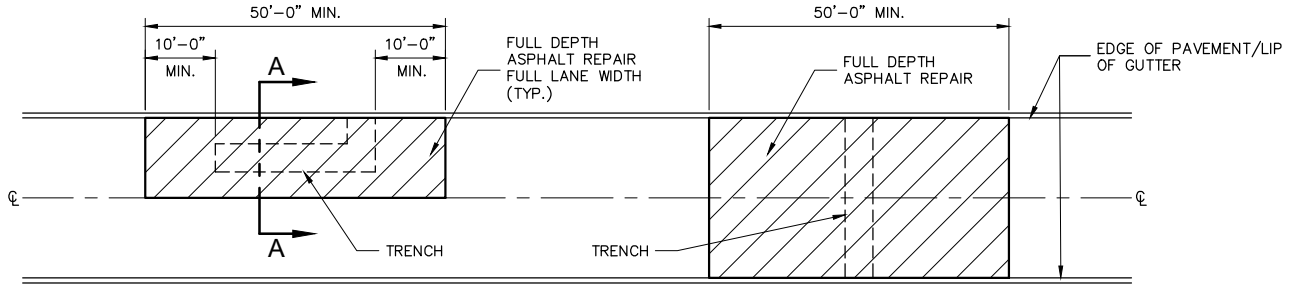

PLAN VIEW

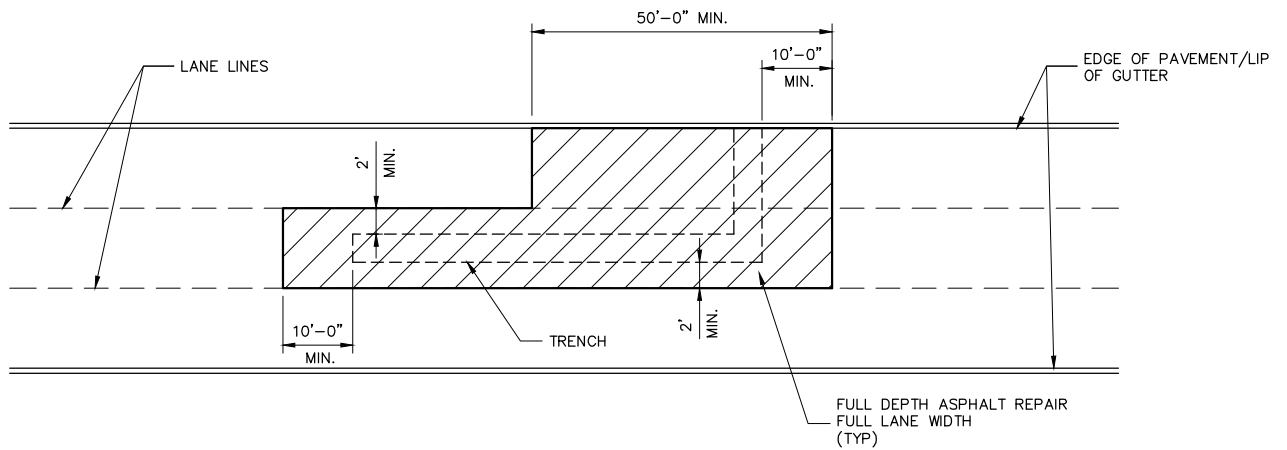

PLAN VIEW

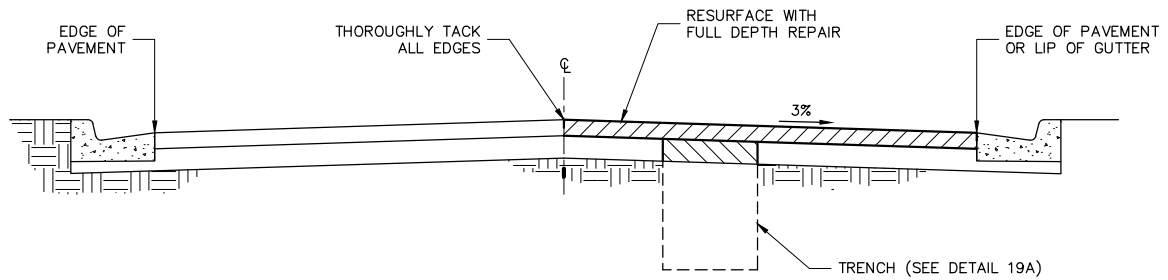

SECTION A-A

NOTES:

1. THIS STANDARD APPLIES TO ALL ROAD CUTS ON PAVEMENT NEWER THAN ROAD CUT MORATORIUM PLUS 5 YEARS.
2. ADJUST ALL VALVE BOXES, MANHOLE RINGS AND COVERS, AND SURVEY MONUMENTS TO FINISH GRADE AND ADD CONCRETE COLLAR PER CITY STANDARDS.
3. FOR MULTIPLE TRENCHES, PROVIDE CONTINUOUS FULL DEPTH REPAIR FROM THE FIRST TRENCH TO THE LAST TRENCH.

BITUMINOUS SURFACE REPAIR

SCALE: N.T.S.

STATEMENT OF USE

THIS DOCUMENT AND ANY ILLUSTRATIONS HEREON ARE PROVIDED AS STANDARD CONSTRUCTION DETAILS WITHIN HOOPER CITY. DEVIATION FROM THIS DOCUMENT REQUIRES APPROVAL OF HOOPER CITY. HOOPER CITY CORPORATION CAN NOT BE HELD LIABLE FOR MISUSE OR CHANGES REGARDING THIS DOCUMENT.

REVISION

NO.	DESCRIPTION	BY	APR.	DATE



**BITUMINOUS SURFACE REPAIR
PLAN AND SECTION VIEWS**

HOOPER CITY
DEVELOPMENT STANDARDS

STANDARD DRAWING NUMBER: **16B**

CAD DWG: TRENCH_SEC
PLOT SCALE: 1 = 96
DRAWN BY: JDM
DESIGN BY: TLA
CHECKED BY: TLA
ADOPTED DATE: NOV 2010

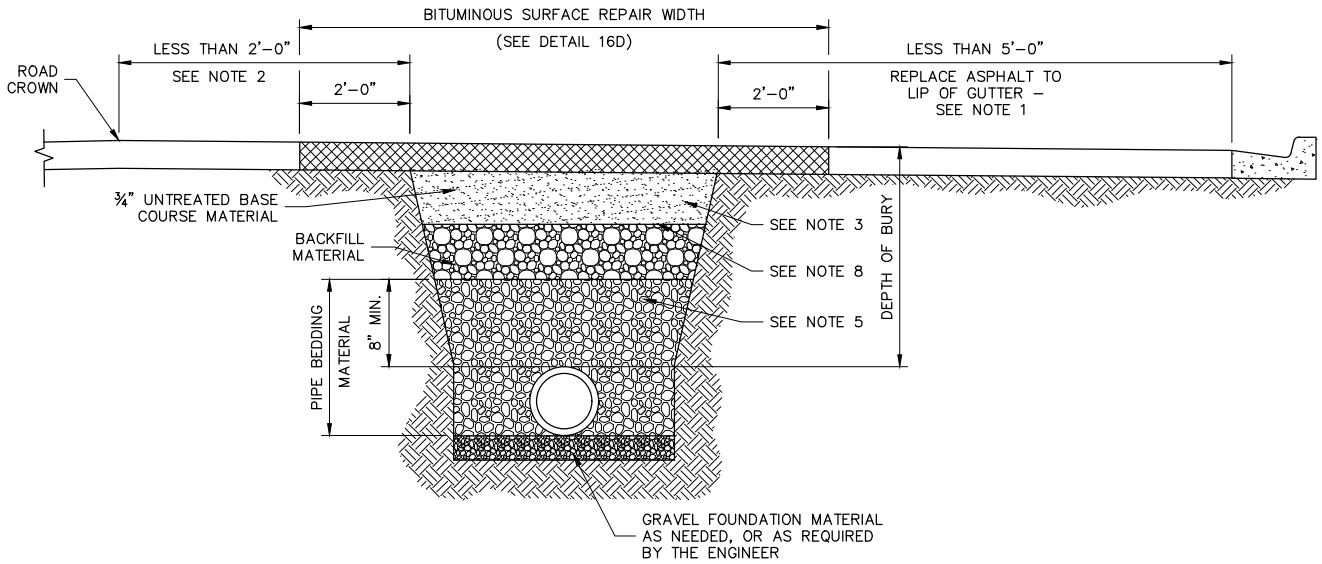

NOTES:

1. WHERE NO CURB & GUTTER EXISTS AND THE EDGE OF THE TRENCH IS LESS THAN 5'-0" FROM THE EXISTING EDGE OF ASPHALT, REPLACE ENTIRE SECTION OF PAVEMENT FROM EDGE OF TRENCH TO EXISTING EDGE OF ASPHALT.
2. WHERE THE EDGE OF THE TRENCH IS LESS THAN 2'-0" FROM THE EXISTING CROWN OF THE ROAD, SAW CUT AT EXISTING CROWN AND REPLACE AFFECTED LANE FULL DEPTH.
3. SAW CUT BITUMINOUS ASPHALT SURFACE WIDER THAN TRENCH ON EACH SIDE FOR FINAL TRENCH REPAIR WHERE BITUMINOUS SURFACE EXISTS. (DETAIL 16D).
4. BITUMINOUS SURFACE IS TO BE 6" OR TO MATCH EXISTING THICKNESS, WHICHEVER IS GREATER FOR STATE ROADS & 3" OR MATCH EXISTING THICKNESS, WHICHEVER IS GREATER FOR OTHER ROADS.
5. FOR TRENCH REPAIR, 3/4" UNTREATED BASE COURSE MATERIAL IS TO BE 12" OR TO MATCH EXISTING THICKNESS, WHICHEVER IS GREATER. FOR NEW ROAD CONSTRUCTION, 3/4" UNTREATED BASE COURSE MATERIAL IS TO BE 10" MIN. OR AS DIRECTED BY THE ENGINEER. BASE COURSE TO BE COMPACTED TO 96% ASTM D-1557.
6. SLOPE TRENCH SIDES TO MEET OSHA SAFETY REGULATIONS. (LATEST REV.)
7. BACKFILL TO BE COMPACTED TO 96% ASTM D-1557.
8. USE GEOTEXTILE FABRIC TO MATCH EXISTING OR WHERE REQUIRED.

BITUMINOUS SURFACE REPAIR & TYPICAL TRENCH SECTION

SCALE: N.T.S.

* NOTE: EXISTING BITUMINOUS SURFACE COURSE OLDER THAN ROAD CUT MORATORIUM PLUS FIVE YEARS

STATEMENT OF USE

THIS DOCUMENT AND ANY ILLUSTRATIONS HEREON ARE PROVIDED AS STANDARD CONSTRUCTION DETAILS WITHIN HOOPER CITY. DEVIATION FROM THIS DOCUMENT REQUIRES APPROVAL OF HOOPER CITY. HOOPER CITY CORPORATION CAN NOT BE HELD LIABLE FOR MISUSE OR CHANGES REGARDING THIS DOCUMENT.

REVISION

NO.	DESCRIPTION	BY	APR.	DATE
▲				
▲				
▲				



BITUMINOUS SURFACE REPAIR & TYPICAL TRENCH SECTION

HOOPER CITY
DEVELOPMENT STANDARDS

STANDARD DRAWING NUMBER:	16C
CAD DWG:	TRENCH_SEC
PLOT SCALE:	1 = 96
DRAWN BY:	JDM
DESIGN BY:	TLA
CHECKED BY:	TLA
ADOPTED DATE:	NOV 2010

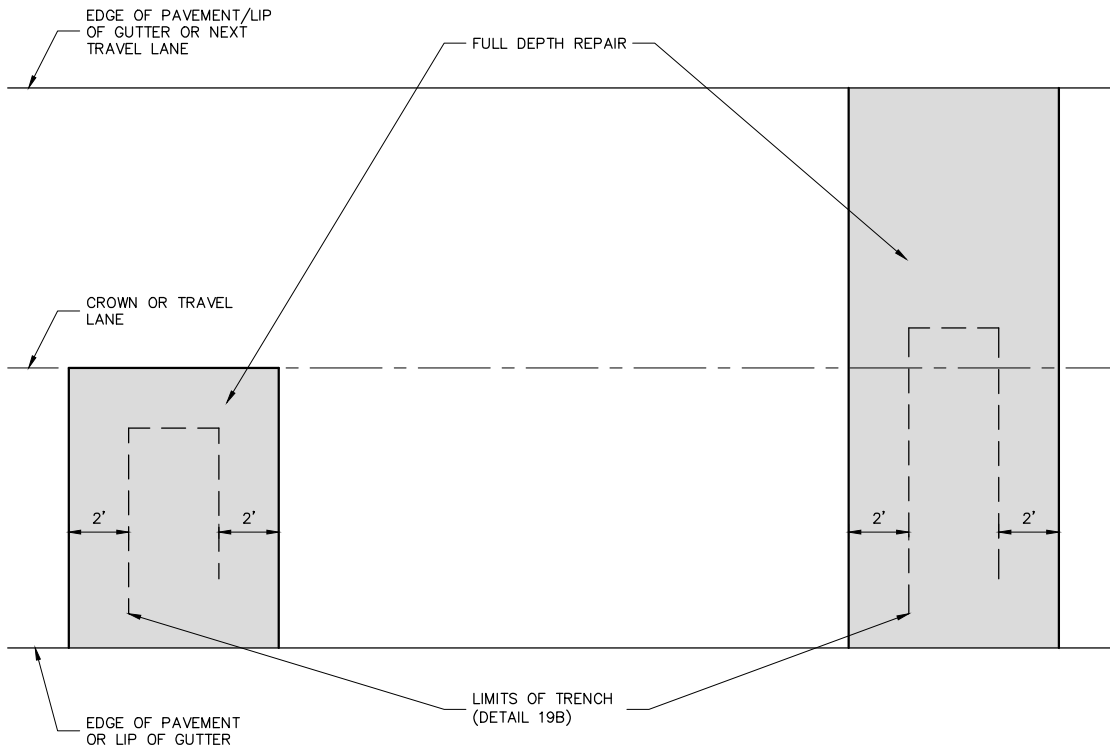

LATERAL (PERPENDICULAR) CUTS

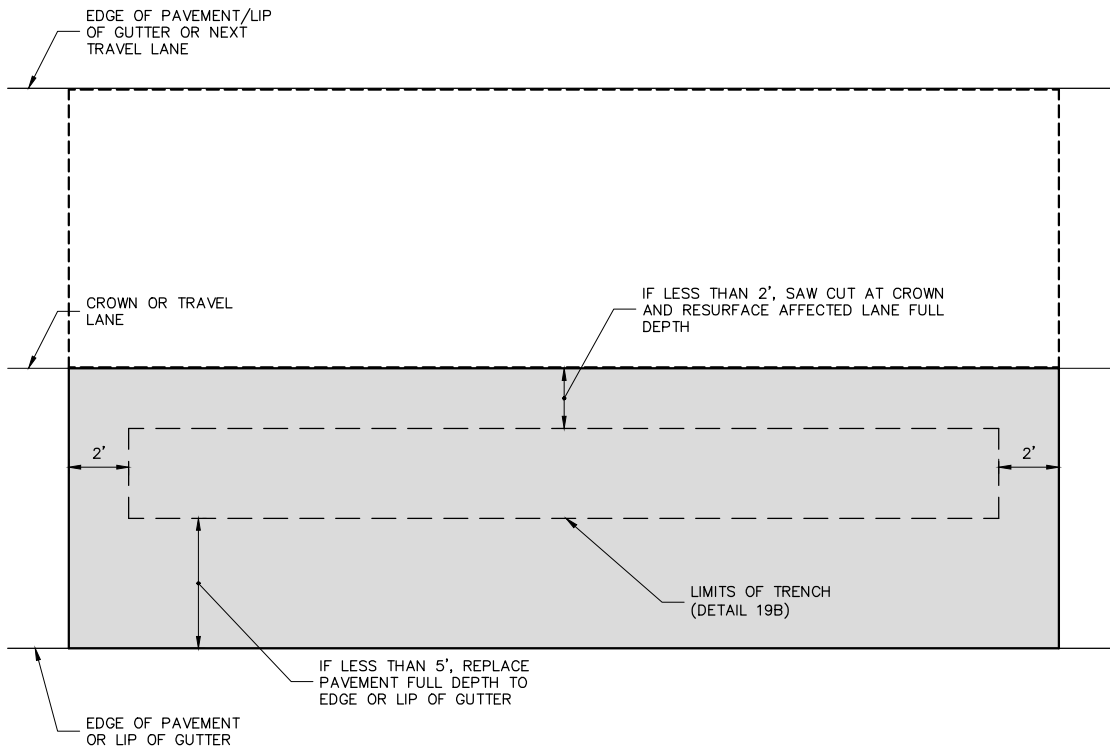

LONGITUDINAL (PARALLEL) CUTS

BITUMINOUS SURFACE REPAIR PLAN VIEWS

SCALE: N.T.S.

STATEMENT OF USE

THIS DOCUMENT AND ANY ILLUSTRATIONS HEREON ARE PROVIDED AS STANDARD CONSTRUCTION DETAILS WITHIN HOOPER CITY. DEVIATION FROM THIS DOCUMENT REQUIRES APPROVAL OF HOOPER CITY. HOOPER CITY CORPORATION CAN NOT BE HELD LIABLE FOR MISUSE OR CHANGES REGARDING THIS DOCUMENT.

REVISION

NO.	DESCRIPTION	BY	APR.	DATE



BITUMINOUS SURFACE REPAIR
PLAN VIEWS

HOOPER CITY
DEVELOPMENT STANDARDS

STANDARD DRAWING NUMBER: **16D**

CAD DWG: TRENCH_SEC
PLOT SCALE: 1 = 96
DRAWN BY: JDM
DESIGN BY: TLA
CHECKED BY: TLA
ADOPTED DATE: NOV 2010

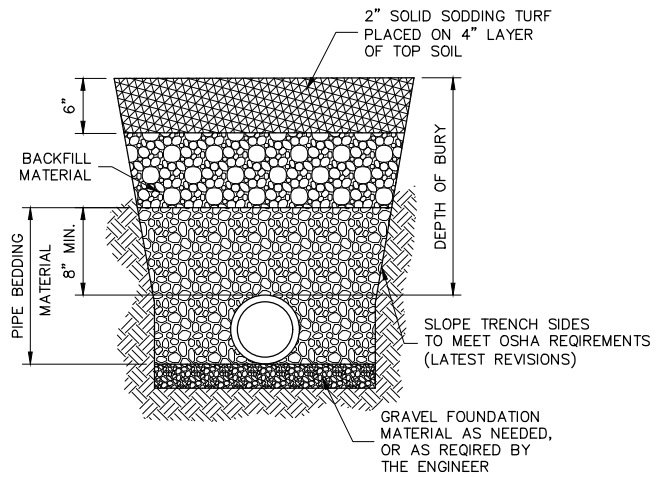

TURF SURFACE TRENCH SECTION

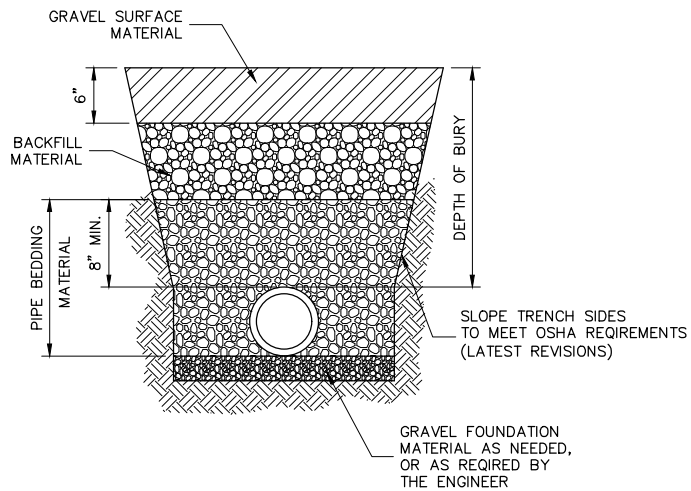

GRAVEL SURFACE TRENCH SECTION

NOTES:

1. SLOPE TRENCH SIDES TO MEET OSHA SAFETY REGULATIONS. (LATEST REV.)
2. BACKFILL TO BE COMPACTED TO 96% ASTM D-1557 IN ROADWAYS AND 90% IN LANDSCAPED AREAS.

NON-BITUMINOUS SURFACE REPAIR - TYPICAL TRENCH SECTIONS

SCALE: N.T.S.

STATEMENT OF USE

THIS DOCUMENT AND ANY ILLUSTRATIONS HEREON ARE PROVIDED AS STANDARD CONSTRUCTION DETAILS WITHIN HOOPER CITY. DEVIATION FROM THIS DOCUMENT REQUIRES APPROVAL OF HOOPER CITY. HOOPER CITY CORPORATION CAN NOT BE HELD LIABLE FOR MISUSE OR CHANGES REGARDING THIS DOCUMENT.

REVISION

NO.	DESCRIPTION	BY	APR.	DATE
▲				
▲				
▲				



NON-BITUMINOUS SURFACE REPAIR
& TYPICAL TRENCH SECTIONS

HOOPER CITY
DEVELOPMENT STANDARDS

STANDARD DRAWING NUMBER: **16E**
 CAD DWG: TRENCH_SEC
 PLOT SCALE: 1 = 96
 DRAWN BY: JDM
 DESIGN BY: TLA
 CHECKED BY: TLA
 ADOPTED DATE: NOV 2010

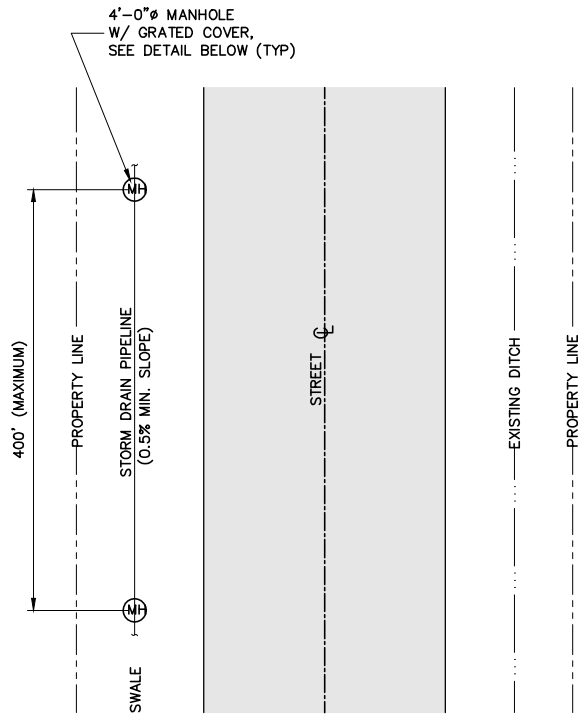

PLAN VIEW
SCALE: N.T.S.

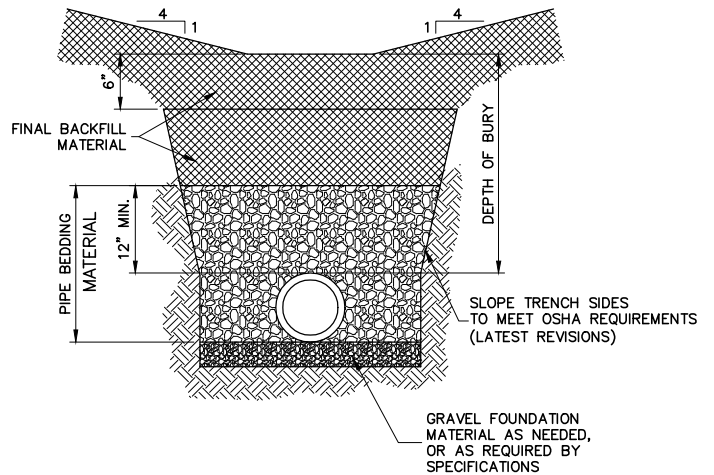

TYPICAL TRENCH DETAIL
SCALE: N.T.S.

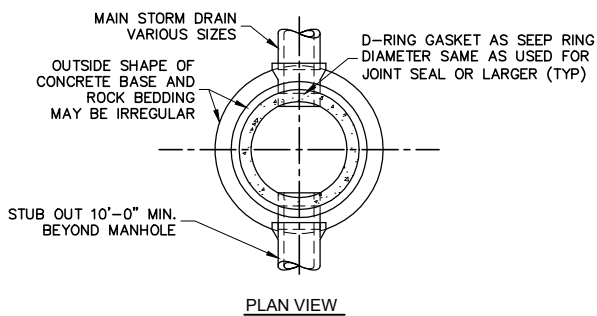

PLAN VIEW

NOTES:
1. DEWATERING SHALL NOT ALLOW PIPING OF FINES.

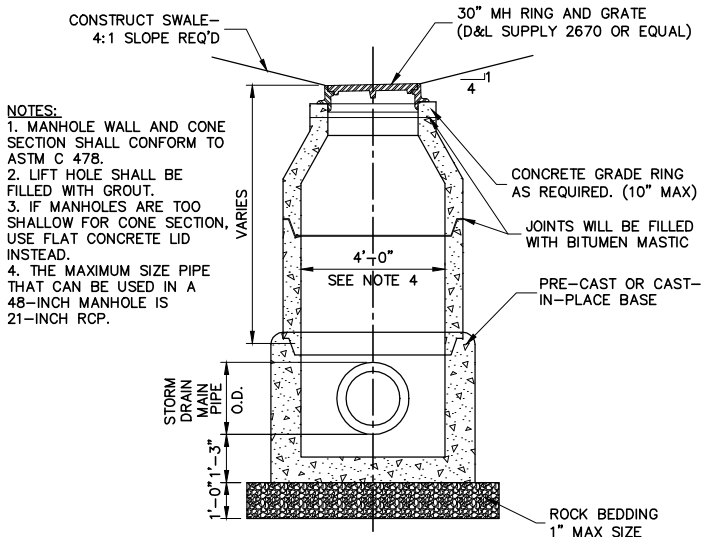

NOTES:
1. MANHOLE WALL AND CONE SECTION SHALL CONFORM TO ASTM C 478.
2. LIFT HOLE SHALL BE FILLED WITH GROUT.
3. IF MANHOLES ARE TOO SHALLOW FOR CONE SECTION, USE FLAT CONCRETE LID INSTEAD.
4. THE MAXIMUM SIZE PIPE THAT CAN BE USED IN A 48-INCH MANHOLE IS 21-INCH RCP.

TYPICAL MANHOLE SECTION
SCALE: N.T.S.

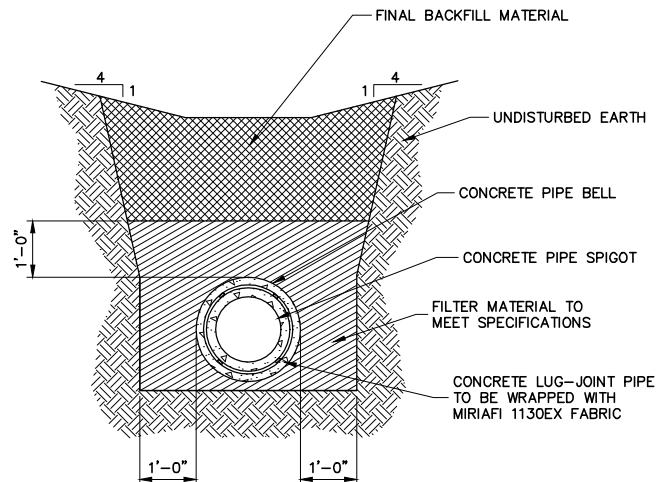

ALTERNATE TRENCH DETAIL-OPEN JOINT
ONLY WHEN APPROVED BY CITY PUBLIC WORKS SCALE: N.T.S.

STATEMENT OF USE

THIS DOCUMENT AND ANY ILLUSTRATIONS HEREON ARE PROVIDED AS STANDARD CONSTRUCTION DETAILS WITHIN HOOPER CITY. DEVIATION FROM THIS DOCUMENT REQUIRES APPROVAL OF HOOPER CITY. HOOPER CITY CORPORATION CAN NOT BE HELD LIABLE FOR MISUSE OR CHANGES REGARDING THIS DOCUMENT.

REVISION

NO.	DESCRIPTION	BY	APR.	DATE



PIPED DRAIN DITCHES WITHIN CITY RIGHTS-OF-WAY (NO CURB & GUTTER)

HOOPER CITY DEVELOPMENT STANDARDS

STANDARD DRAWING NUMBER:	17A
CAD DWG: PIPED_DITCHES_1	
PLOT SCALE:	1 = 1
DRAWN BY:	ASC
DESIGN BY:	TLA
CHECKED BY:	TLA
ADOPTED DATE:	NOV 2003

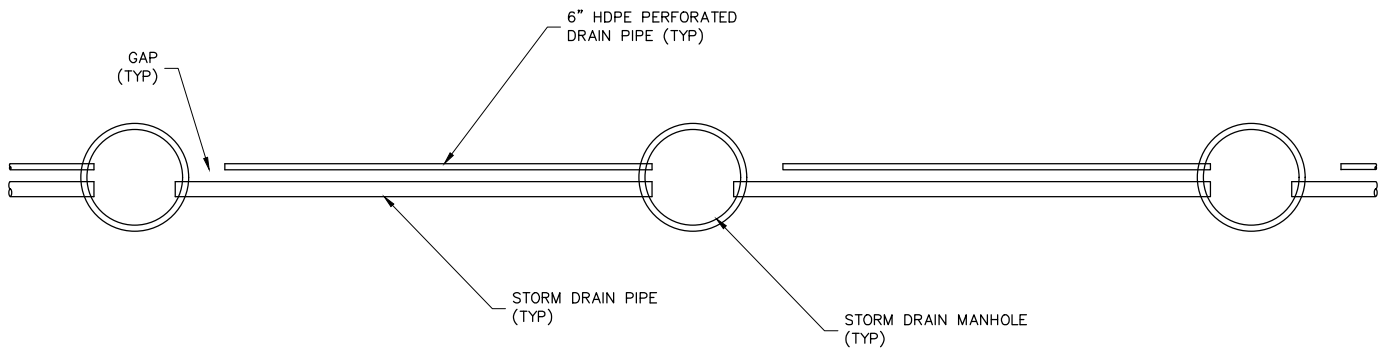

TYPICAL PLAN VIEW

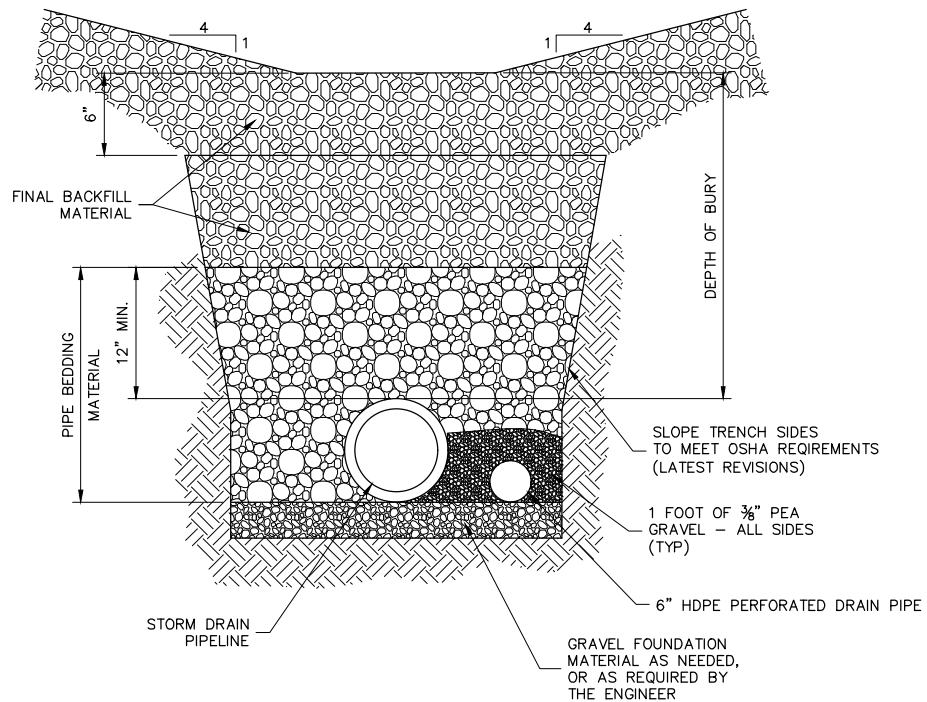

STORM DRAIN PIPING WITH ADJACENT DRAIN PIPE

SCALE: N.T.S.

STATEMENT OF USE

THIS DOCUMENT AND ANY ILLUSTRATIONS HEREON ARE PROVIDED AS STANDARD CONSTRUCTION DETAILS WITHIN HOOPER CITY. DEVIATION FROM THIS DOCUMENT REQUIRES APPROVAL OF HOOPER CITY. HOOPER CITY CORPORATION CAN NOT BE HELD LIABLE FOR MISUSE OR CHANGES REGARDING THIS DOCUMENT.

REVISION

NO.	DESCRIPTION	BY	APR.	DATE
▲				
▲				
▲				



STORM DRAIN PIPING WITH ADJACENT DRAIN PIPE

HOOPER CITY DEVELOPMENT STANDARDS

STANDARD DRAWING NUMBER: **17B**

CAD DWG: PIPE_DITCHES_2
 PLOT SCALE: 1 = 96
 DRAWN BY: JDM
 DESIGN BY: TLA
 CHECKED BY: TLA
 ADOPTED DATE: JAN 2020

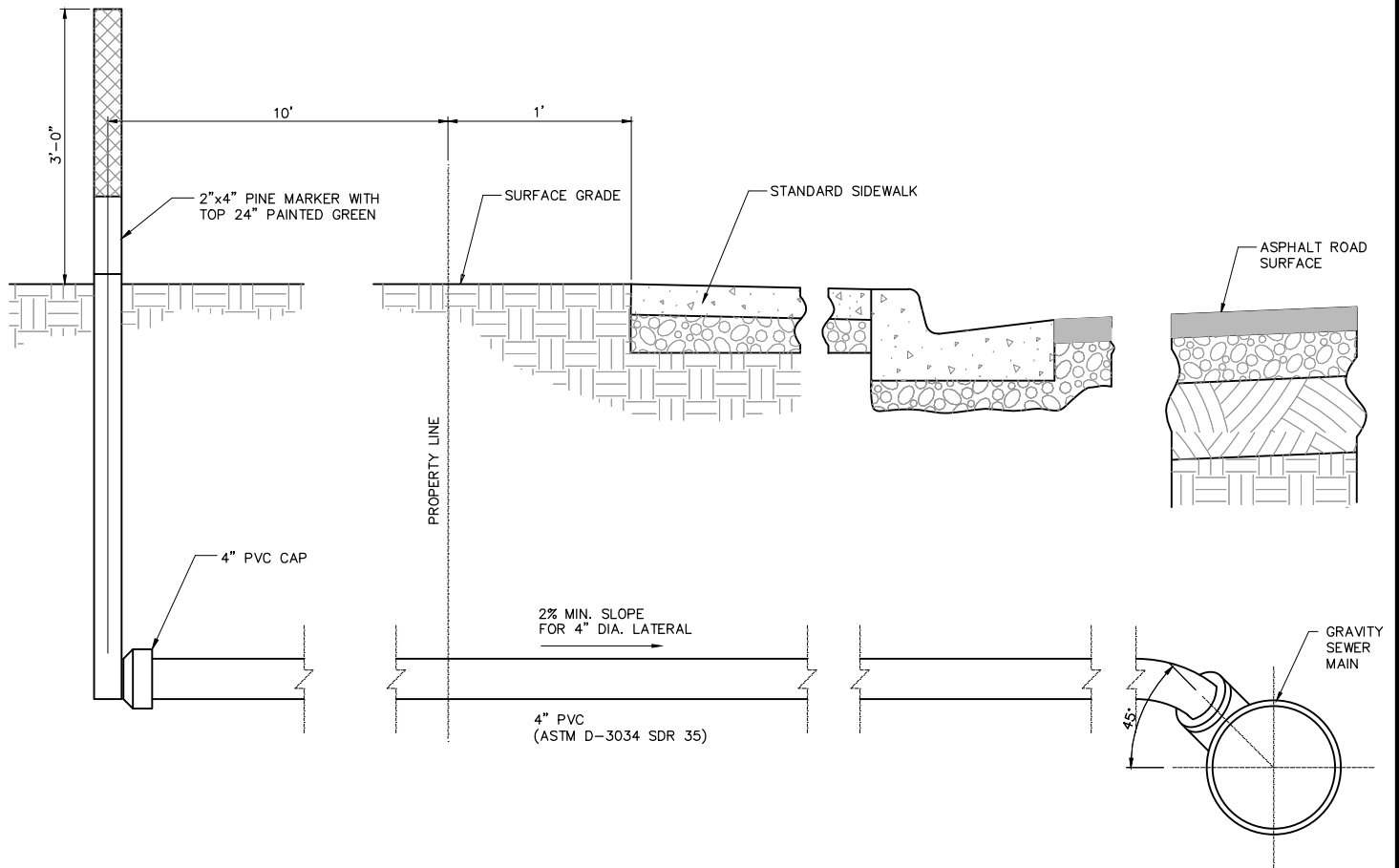

STUB FOR NEW CONSTRUCTION

NOTES FOR CONNECTING TO NEW SEWER MAIN:

1. CONNECTION TO MAIN SHALL BE BY WYE'S OR TEE'S INSTALLED AS PART OF THE SEWER MAIN CONSTRUCTION.
2. HOOPER CITY MAINTAINS THE SEWER LATERAL FROM THE SEWER MAIN TO THE STREET RIGHT-OF-WAY LINE. THE PROPERTY OWNER MAINTAINS THE SEWER LATERAL FROM THE BUILDING TO THE STREET RIGHT-OF-WAY LINE. A PLUGGED LATERAL IS THE PROPERTY OWNERS RESPONSIBILITY FROM THE BUILDING TO THE SEWER MAIN.

STATEMENT OF USE
 THIS DOCUMENT AND ANY ILLUSTRATIONS HEREON ARE PROVIDED AS STANDARD CONSTRUCTION DETAILS WITHIN HOOPER CITY. DEVIATION FROM THIS DOCUMENT REQUIRES APPROVAL OF HOOPER CITY. HOOPER CITY CORPORATION CAN NOT BE HELD LIABLE FOR MISUSE OR CHANGES REGARDING THIS DOCUMENT.

REVISION			
NO.	DESCRIPTION	BY	APR. DATE



**TYPICAL SEWER LATERAL
 NEW CONSTRUCTION - (NON VACUUM)**

**HOOPER CITY
 DEVELOPMENT STANDARDS**

STANDARD DRAWING NUMBER:	18A
CAD DWG: SEW_LAT_GRAV	
PLOT SCALE:	1 = 1
DRAWN BY:	JDM
DESIGN BY:	TLA
CHECKED BY:	TLA
ADOPTED DATE:	NOV 2005

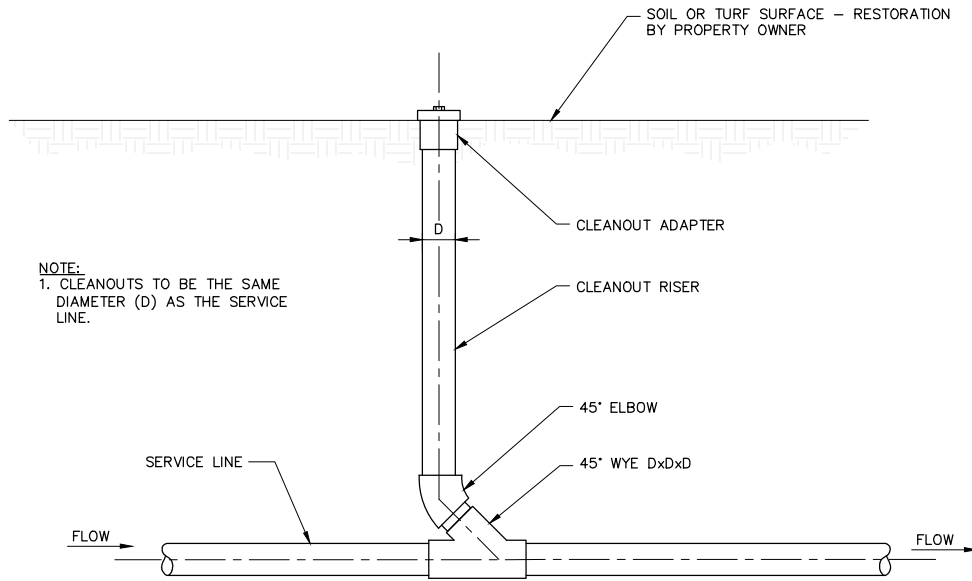

ELEVATION VIEW

TYPICAL GRAVITY SEWER CLEANOUT DETAIL

SCALE: N.T.S.

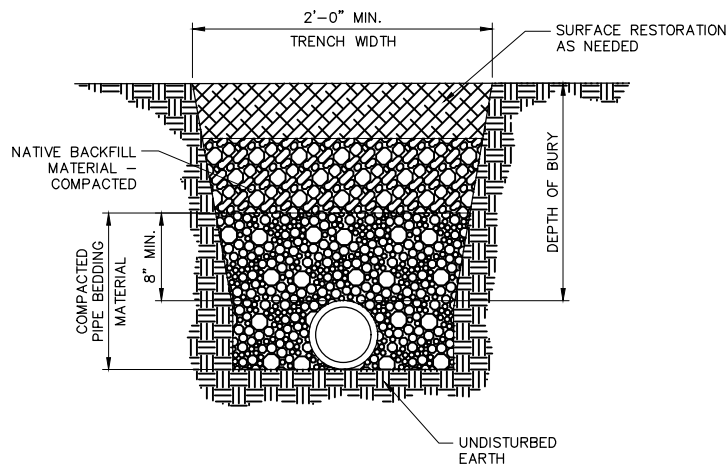

TYPICAL GRAVITY SEWER TRENCH SECTION

SCALE: N.T.S.

STATEMENT OF USE

THIS DOCUMENT AND ANY ILLUSTRATIONS HEREON ARE PROVIDED AS STANDARD CONSTRUCTION DETAILS WITHIN HOOPER CITY. DEVIATION FROM THIS DOCUMENT REQUIRES APPROVAL OF HOOPER CITY. HOOPER CITY CORPORATION CAN NOT BE HELD LIABLE FOR MISUSE OR CHANGES REGARDING THIS DOCUMENT.

REVISION

NO.	DESCRIPTION	BY	APR.	DATE
▲				
▲				
▲				



TYPICAL GRAVITY SEWER LATERAL
CLEANOUT DETAIL & TRENCH SECTION

HOOPER CITY
DEVELOPMENT STANDARDS

STANDARD DRAWING NUMBER: **18B**

CAD DWG: SEWER_LAT
PLOT SCALE: 1 = 48
DRAWN BY: JDM
DESIGN BY: TLA
CHECKED BY: TLA
ADOPTED DATE: JUN 2005

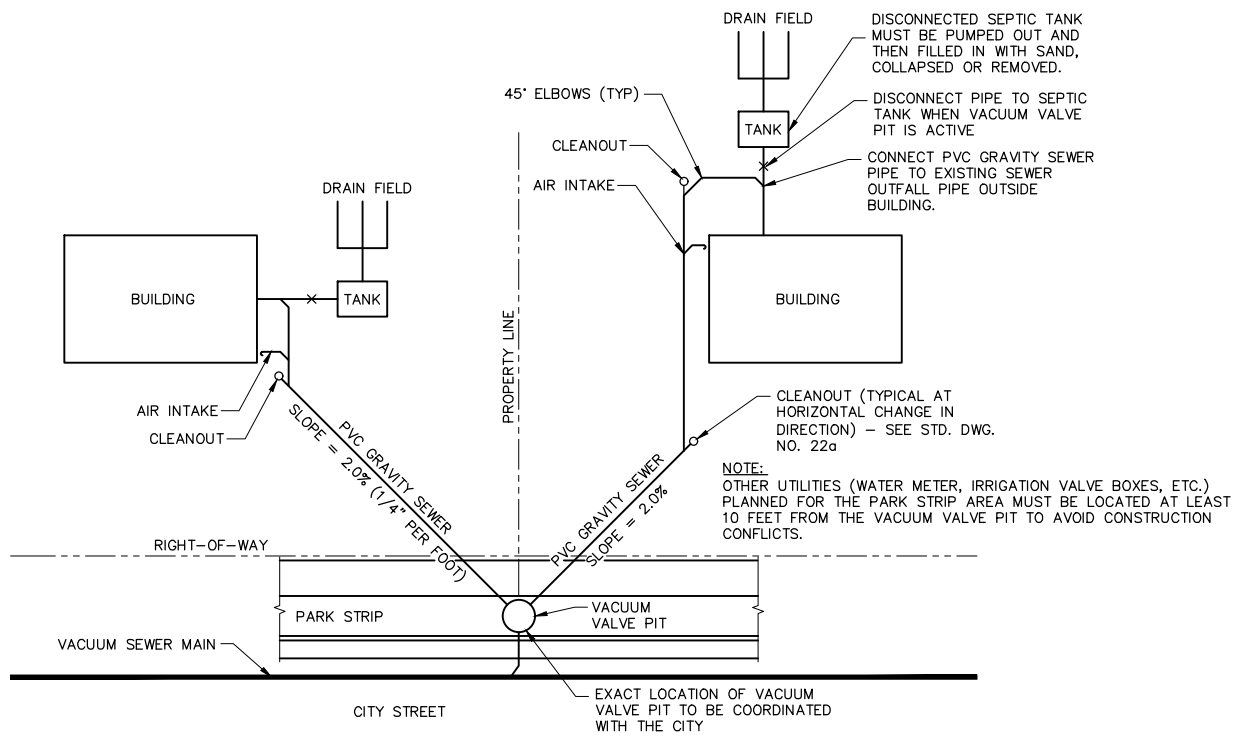

PLAN VIEW

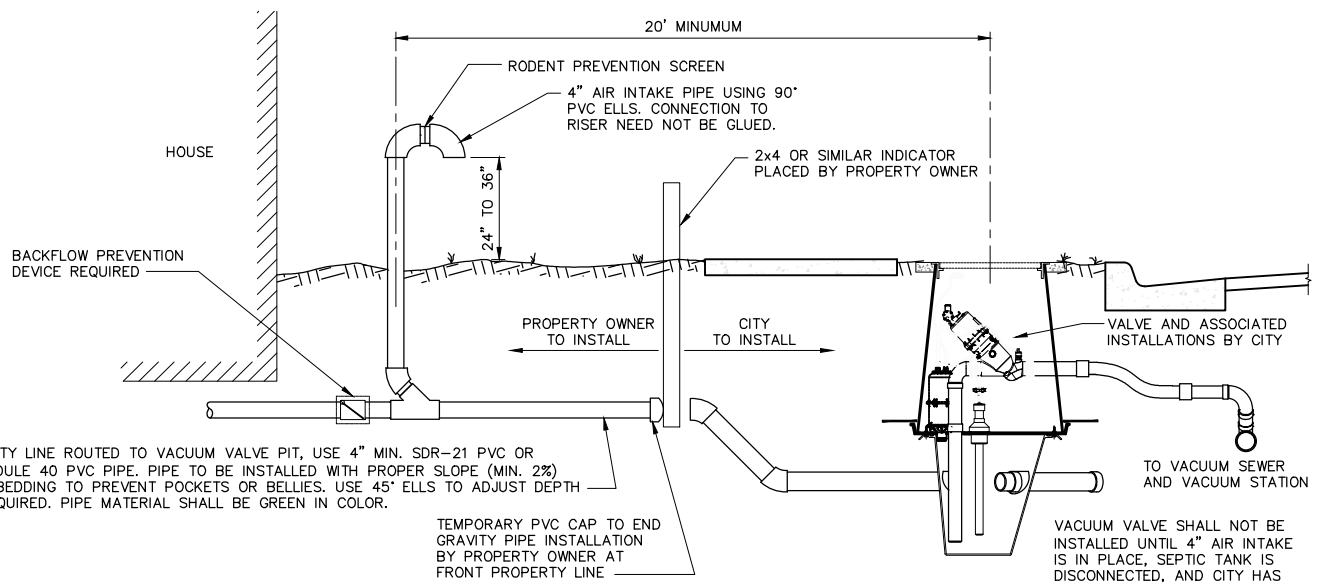

FRONT PROFILE VIEW

- NOTES:**
- 1: PROPERTY OWNER TO INSTALL A GRAVITY SEWER PIPE (SERVICE LATERAL) FROM THE EXISTING SEWER OUTFALL FROM THEIR RESIDENCE OR OTHER BUILDING TO THE FRONT PROPERTY LINE ALONG AN EXISTING CITY STREET.
 - 2: EACH SEPARATELY-OWNED BUILDING SHALL HAVE ITS OWN SEPARATE GRAVITY SEWER SERVICE LATERAL TO THE VALVE PIT.
 - 3: THE LOCATION OF THE VALVE PIT SHALL BE DETERMINED BY THE CITY. IF THE SEWER SERVICE LATERAL IS INSTALLED PRIOR TO THE INSTALLATION OF THE VALVE PIT, COORDINATE WITH PUBLIC WORKS FOR THE PLANNED LOCATION OF THE VALVE PIT.
 - 4: VALVE PIT LIDS SHALL NOT BE BURIED, COVERED, NOR ACCESS OTHERWISE OBSTRUCTED BY ANY ACTION OF THE PROPERTY OWNER.
 - 5: IT IS ILLEGAL TO DISCHARGE ANY FLOWS OTHER THAN SANITARY SEWER FROM THE PRIMARY STRUCTURE'S MAIN OUTFALL INTO THE SEWER SERVICE LATERAL, INCLUDING, BUT NOT LIMITED TO, ROOF DRAINS, SUMP DRAINS, LAND DRAINS, ETC.
 - 6: 90-DEGREE ELBOWS AND TEE FITTINGS SHALL NOT BE PERMITTED FOR USE ON THE GRAVITY SEWER SERVICE LATERAL. A WYE FITTING SHALL BE USED INSTEAD OF A TEE. TWO 45 DEGREE ELBOWS SEPARATED BY A 3-FOOT PIPE LENGTH SHALL BE USED INSTEAD OF A 90 DEGREE ELBOW.
 - 7: A PVC SEWER CLEANOUT AS SHOWN IN STANDARD DRAWING 22a SHALL BE REQUIRED AT EVERY HORIZONTAL CHANGE IN DIRECTION, AND EVERY 100-FOOT MAXIMUM ALONG THE SERVICE LATERAL.
 - 8: THE ENTIRE GRAVITY SEWER SERVICE LATERAL MUST BE INSPECTED AND APPROVED BY THE CITY PUBLIC WORKS OFFICIALS BEFORE BACKFILLING AND BEFORE THE VACUUM VALVE IS INSTALLED IN THE VALVE PIT.

TYPICAL GRAVITY SEWER LATERAL INSTALLATION
 BUILDING OUTFALL TO VACUUM VALVE PIT

STATEMENT OF USE
 THIS DOCUMENT AND ANY ILLUSTRATIONS HEREON ARE PROVIDED AS STANDARD CONSTRUCTION DETAILS WITHIN HOOPER CITY. DEVIATION FROM THIS DOCUMENT REQUIRES APPROVAL OF HOOPER CITY. HOOPER CITY CORPORATION CAN NOT BE HELD LIABLE FOR MISUSE OR CHANGES REGARDING THIS DOCUMENT.

REVISION			
NO.	DESCRIPTION	BY	APR. DATE



TYPICAL GRAVITY SEWER LATERAL (VACUUM) INSTALLATION DETAILS

HOOPER CITY
 DEVELOPMENT STANDARDS

STANDARD DRAWING NUMBER:	18C
CAD DWG:	SEWER_LAT
PLOT SCALE:	1 = 48
DRAWN BY:	JDM
DESIGN BY:	TLA
CHECKED BY:	TLA
ADOPTED DATE:	JUN 2005

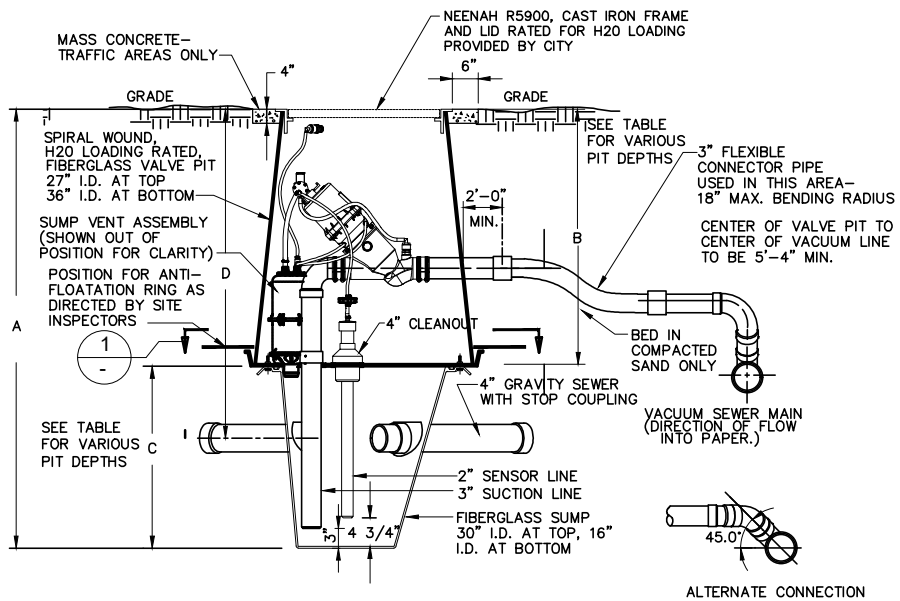

VALVE PIT DEPTH TABLE				
TOTAL PIT DEPTH A	VALVE PIT HEIGHT B	SUMP HEIGHT C	4" INLET DEPTH D	MODEL NUMBER
5'	2.5'	2.5'	3.5'	VP3030WT
6'	3.5'	2.5'	4.5'	VP4230WT
7'	3.5'	3.5'	5.5'	VP4242
8'	4.5'	3.5'	6.5'	VP5442
10'	4.5'	5.5'	8.5'	VP5466

VALVE PIT
SCALE: N.T.S.

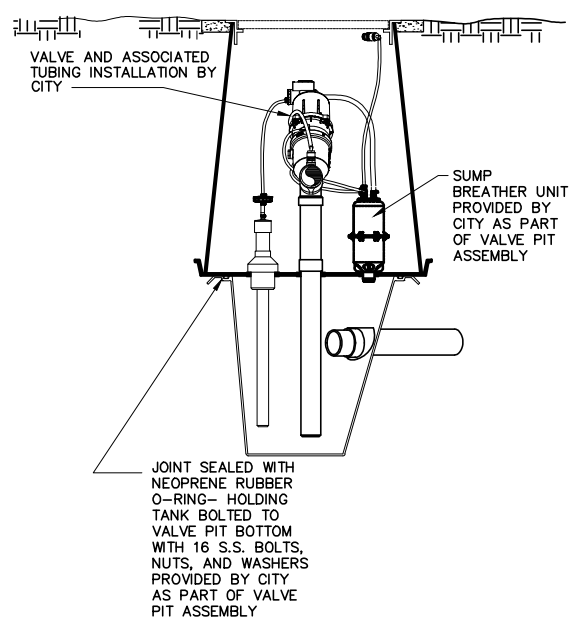

VALVE PIT TUBING DIAGRAM
SCALE: N.T.S.

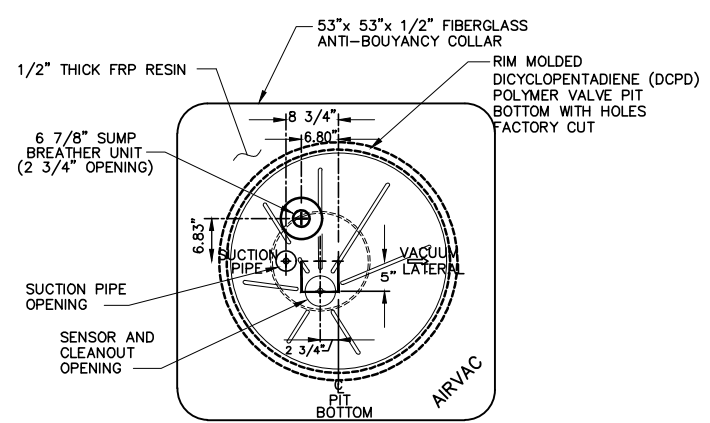

ANTI-BOUYANCY COLLAR 1
SCALE: N.T.S.

STATEMENT OF USE
THIS DOCUMENT AND ANY ILLUSTRATIONS HEREON ARE PROVIDED AS STANDARD CONSTRUCTION DETAILS WITHIN HOOPER CITY. DEVIATION FROM THIS DOCUMENT REQUIRES APPROVAL OF HOOPER CITY. HOOPER CITY CORPORATION CAN NOT BE HELD LIABLE FOR MISUSE OR CHANGES REGARDING THIS DOCUMENT.

NO.	REVISION	BY	APR.	DATE



VACUUM SEWER DETAILS

HOOPER CITY
DEVELOPMENT STANDARDS

STANDARD DRAWING NUMBER: **19A**

CAD DWG: VALVE_PIT
PLOT SCALE: 1 = 48
DRAWN BY: JDM
DESIGN BY: TLA
CHECKED BY: TLA
ADOPTED DATE: JUN 2005

NOTES:

1. ALL HOLES IN VALVE PIT AND PIT BOTTOM ARE FACTORY CUT. ALL GRAVITY LINE CONNECTION OPENINGS IN THE SUMP ARE FIELD CUT.
2. WHEN INSTALLING ANY PIPE THROUGH A GROMMET USE ONLY WATER OR MILD DETERGENT AS A LUBRICANT
3. CITY SHALL INSTALL VACUUM VALVE WHEN HOME GRAVITY LINE IS COMPLETED AND AIR INTAKE PIPING IS IN PLACE AND COUPONS ARE ACCOUNTED.
4. INTERNAL SUMP BREATHER IS TO BE EQUIPPED WITH AUTOMATIC SHUT OFF DEVICES TO PREVENT LIQUID CONTAMINATION OF THE CONTROLLER AND INTERFACE VALVE DURING AN EMERGENCY HIGH LIQUID LEVEL EVENT. THESE DEVICES SHALL BE POSITIVE SEALING, SHALL NOT INHIBIT THE VALVE'S PERFORMANCE UNDER NORMAL CONDITIONS AND SHALL RESET AUTOMATICALLY WHEN RECOVERING FROM AN EMERGENCY HIGH LIQUID LEVEL EVENT.
5. 3" SERVICE LENGTH SHALL NOT EXCEED 300 FEET.

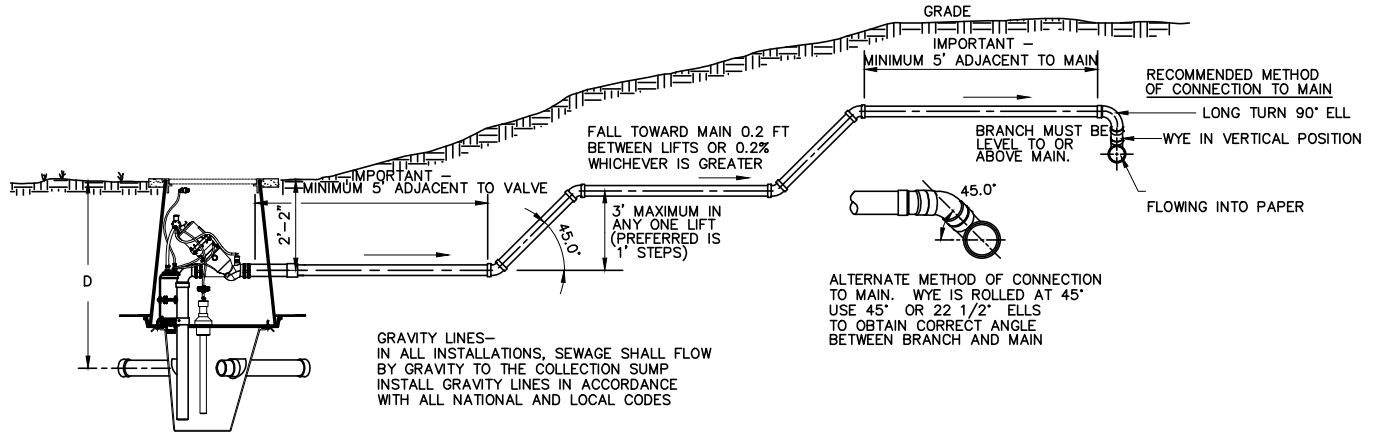

GRAVITY LINES—
IN ALL INSTALLATIONS, SEWAGE SHALL FLOW
BY GRAVITY TO THE COLLECTION SUMP
INSTALL GRAVITY LINES IN ACCORDANCE
WITH ALL NATIONAL AND LOCAL CODES

ALTERNATE METHOD OF CONNECTION
TO MAIN. WYE IS ROLLED AT 45°
USE 45° OR 22 1/2° ELLS
TO OBTAIN CORRECT ANGLE
BETWEEN BRANCH AND MAIN

NOTE:

THE PVC STOP COUPLING CAN BE MADE BY CUTTING OFF
4" OF A 4" PVC, SLICING ONE SIDEWALL OF THE CUT
PIPE PIECE TO ALLOW THE DIAMETER TO EXPAND, SLIDE
IT OVER THE BEVELED END OF THE 4" LATERAL, GLUE IT
4" FROM THE BEVELED END.

LIFT DETAILS FOR 3" SERVICE LATERAL

SCALE: N.T.S.

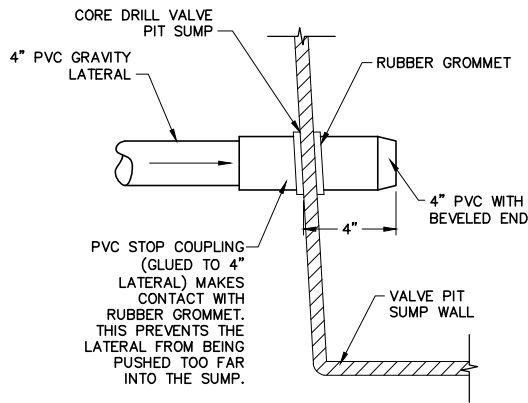

GRAVITY LATERAL CONNECTION
TO VALVE PIT SUMP

SCALE: N.T.S.

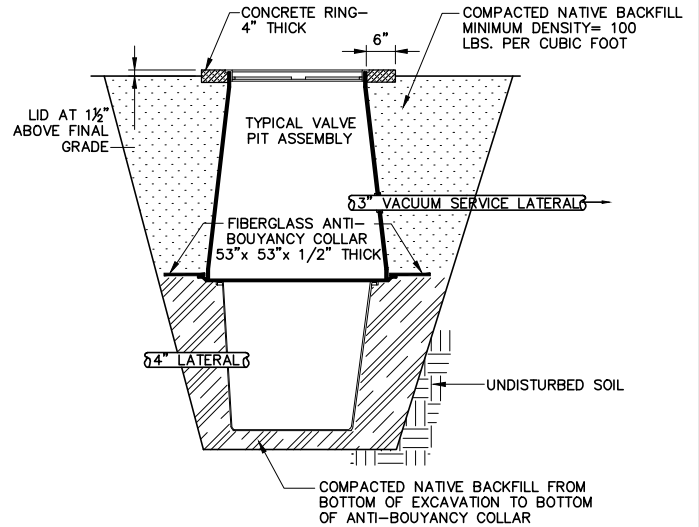

VALVE PIT BEDDING AND BACK FILL

SCALE: N.T.S.

STATEMENT OF USE

THIS DOCUMENT AND ANY ILLUSTRATIONS HEREON ARE PROVIDED AS STANDARD CONSTRUCTION
DETAILS WITHIN HOOPER CITY. DEVIATION FROM THIS DOCUMENT REQUIRES APPROVAL OF
HOOPER CITY. HOOPER CITY CORPORATION CAN NOT BE HELD LIABLE FOR MISUSE OR
CHANGES REGARDING THIS DOCUMENT.

REVISION

NO.	DESCRIPTION	BY	APR.	DATE



Engineers • Surveyors • Planners

VACUUM SEWER DETAILS

HOOPER CITY
DEVELOPMENT STANDARDS

STANDARD
DRAWING
NUMBER: **19B**

CAD DWG: VALVE_PIT
PLOT SCALE: 1 = 48
DRAWN BY: JDM
DESIGN BY: TLA
CHECKED BY: TLA
ADOPTED DATE: JUN 2005

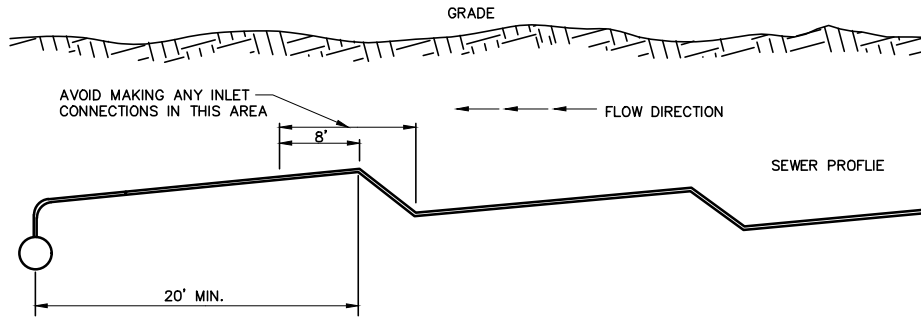

CONNECTION TO MAIN PROFILE
SCALE: N.T.S.

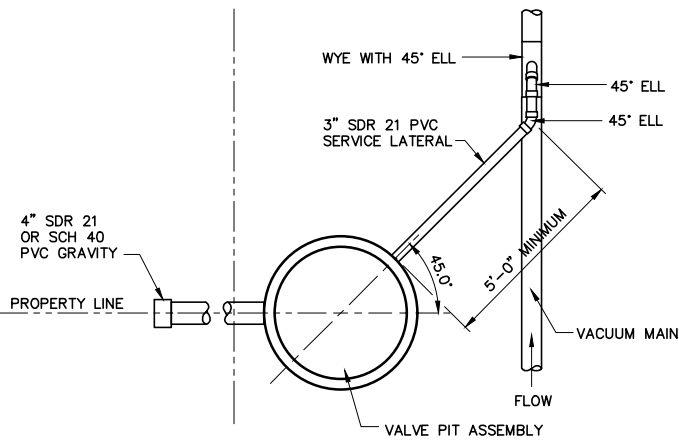

OPTIONAL PLACEMENT FOR VALVE PIT WITH SINGLE CONNECTION
SCALE: N.T.S.

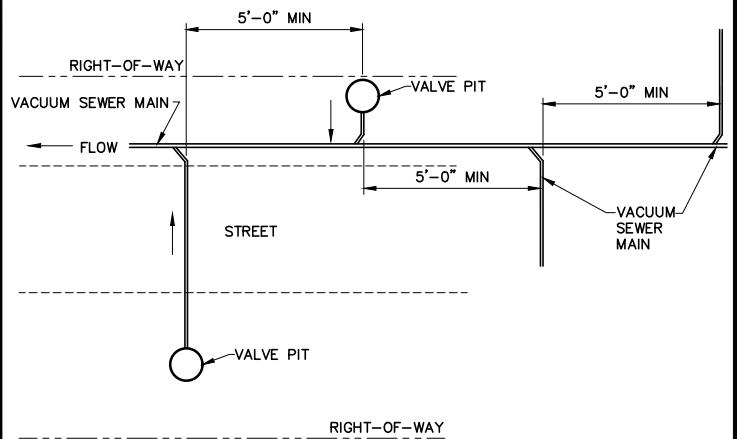

CONNECTION TO MAIN SPACING REQUIREMENTS
SCALE: N.T.S.

STATEMENT OF USE

THIS DOCUMENT AND ANY ILLUSTRATIONS HEREON ARE PROVIDED AS STANDARD CONSTRUCTION DETAILS WITHIN HOOPER CITY. DEVIATION FROM THIS DOCUMENT REQUIRES APPROVAL OF HOOPER CITY. HOOPER CITY CORPORATION CAN NOT BE HELD LIABLE FOR MISUSE OR CHANGES REGARDING THIS DOCUMENT.

REVISION

NO.	DESCRIPTION	BY	APR.	DATE
▲				
▲				
▲				



VACUUM SEWER DETAILS

HOOPER CITY
DEVELOPMENT STANDARDS

STANDARD DRAWING NUMBER: **19C**
CAD DWG: VALVE PIT 1
PLOT SCALE: 1 = 48
DRAWN BY: JDM
DESIGN BY: TLA
CHECKED BY: TLA
ADOPTED DATE: JUN 2005

IMPORTANT!
EACH HOUSE GRAVITY LATERAL
MUST BE INDIVIDUALLY
CONNECTED TO COLLECTION
SUMP OF VALVE PIT

NOTE: FOR A SINGLE SERVICE
ONLY ONE 4" GRAVITY STUB
SHALL BE INSTALLED.

OPTIONAL 3" FLEXIBLE PVC (98" LONG)
AS NECESSARY TO REDUCE MULTIPLE
FITTINGS AROUND OBSTRUCTIONS OR TO
MATCH TWO RIGID PIPES SET IN PLACE.

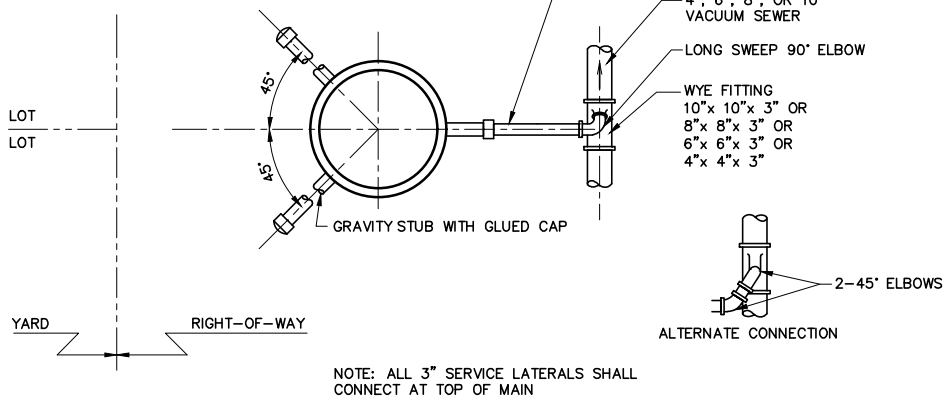

**PREFERRED PLACEMENT FOR VALVE PIT
WITH 1 OR 2 CONNECTIONS**
SCALE: N.T.S.

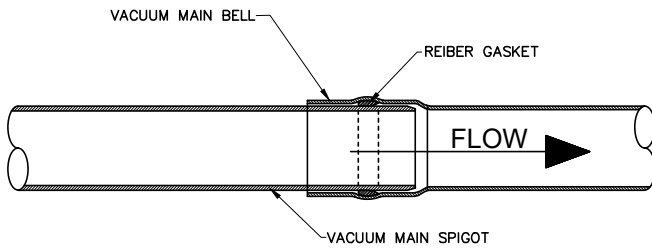

**ALTERNATE VACUUM MAIN BELL CONNECTION
WITH FLOW DIRECTION**
SCALE: N.T.S.

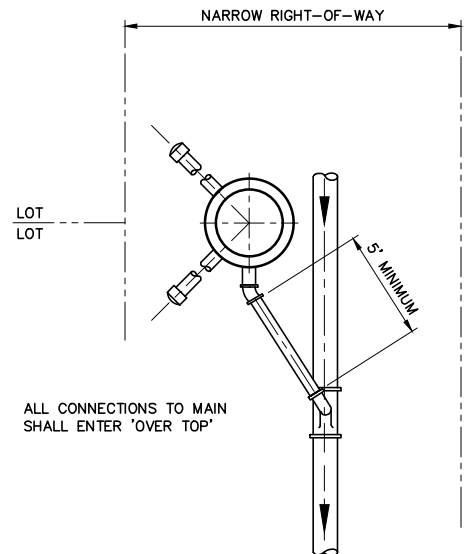

**OPTIONAL PLACEMENT FOR VALVE PIT
NARROW RIGHT-OF-WAY**
SCALE: N.T.S.

STATEMENT OF USE

THIS DOCUMENT AND ANY ILLUSTRATIONS HEREON ARE PROVIDED AS STANDARD CONSTRUCTION DETAILS WITHIN HOOPER CITY. DEVIATION FROM THIS DOCUMENT REQUIRES APPROVAL OF HOOPER CITY. HOOPER CITY CORPORATION CAN NOT BE HELD LIABLE FOR MISUSE OR CHANGES REGARDING THIS DOCUMENT.

REVISION

NO.	DESCRIPTION	BY	APR.	DATE
▲				
▲				
▲				



VACUUM SEWER DETAILS

HOOPER CITY
DEVELOPMENT STANDARDS

STANDARD DRAWING NUMBER: **19D**
CAD DWG: VALVE PIT 1
PLOT SCALE: 1 = 48
DRAWN BY: JDM
DESIGN BY: TLA
CHECKED BY: TLA
ADOPTED DATE: JUN 2005

DIVISION VALVE SUPPORT INFORMATION

VALVE SIZE	MIN. SUPPORT SIZE
4"	1" THICK X 1.75' SQUARE
6"	1" THICK X 2.25' SQUARE
8"	1" THICK X 3.00' SQUARE
10"	1" THICK X 3.50' SQUARE

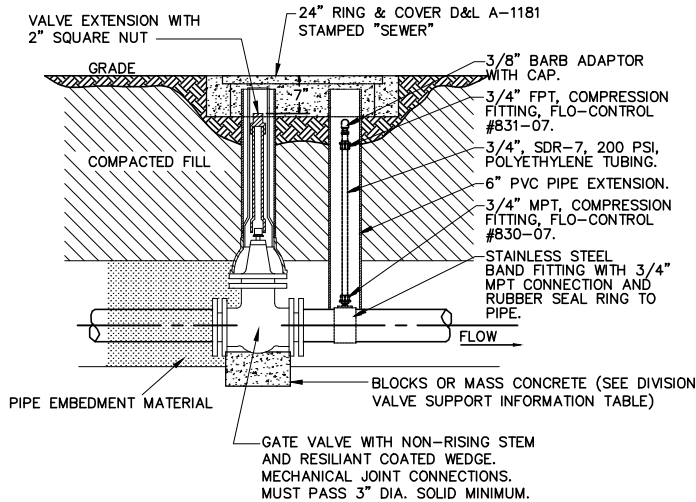

DIVISION VALVE AND GAUGE TAP

SCALE: N.T.S.

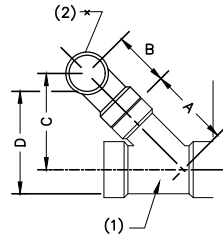
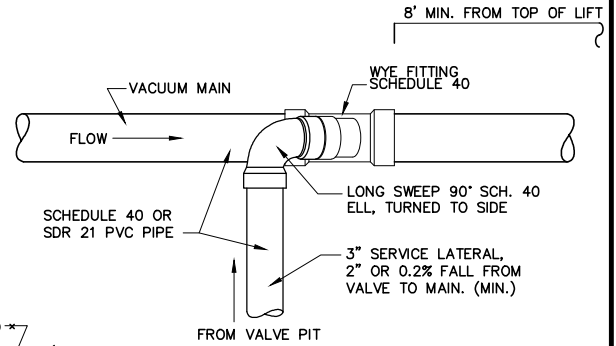

- DIMENSIONS BASED ON SPEARS MANUFACTURING
- (1) 45 DEG WYE, SOCKET x SOCKET x SOCKET
 - (2) 90 DEG ELL, SOCKET x SOCKET

WYE SIZE	A	B	C	D- INVERT
4 x 4 x 3	9 1/4"	3 25/32"	9.32"	0.78'
6 x 6 x 3	10 1/2"	3 25/32"	10.21"	0.85'
8 x 8 x 3	13"	3 25/32"	11.86"	1.00'
10 x 10 x 3	14 3/8"	3 25/32"	12.84"	1.10'

PREFERRED VACUUM SERVICE CONNECTION TO MAIN

SCALE: N.T.S.

WYE SIZE A B C D- INVERT

4 x 4 x 4	8 3/4"	3 5/16"	8.53"	0.71'
4 x 4 x 3	9 1/4"	3 1/16"	8.70"	0.73'
6 x 6 x 6	12 1/8"	5 9/16"	12.5"	1.04'
6 x 6 x 4	10"	3 5/16"	9.41"	0.78'
6 x 6 x 3	10 1/2"	3 1/16"	9.59"	0.80'
8 x 8 x 8	18 3/4"	6 13/16"	18.07"	1.52'
8 x 8 x 6	16 1/4"	5 9/16"	15.42"	1.30'
8 x 8 x 4	14 1/4"	3 5/16"	12.42"	1.05'
8 x 8 x 3	13"	3 1/16"	11.36"	0.99'
10 x 10 x 10	22 3/8"	8 19/32"	21.90"	1.89'
10 x 10 x 8	20 1/4"	6 13/16"	19.13"	1.61'
10 x 10 x 6	17 3/4"	5 9/16"	16.46"	1.42'
10 x 10 x 4	15 3/4"	3 5/16"	13.48"	1.18'
10 x 10 x 3	14 3/4"	3 1/16"	12.33"	1.08'

DIMENSIONS BASED ON SPEARS MANUFACTURING

- (1) 45 DEG WYE, SOCKET x SOCKET x SOCKET
- (2) 45 DEG ELL, SOCKET x SOCKET

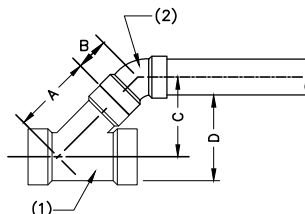
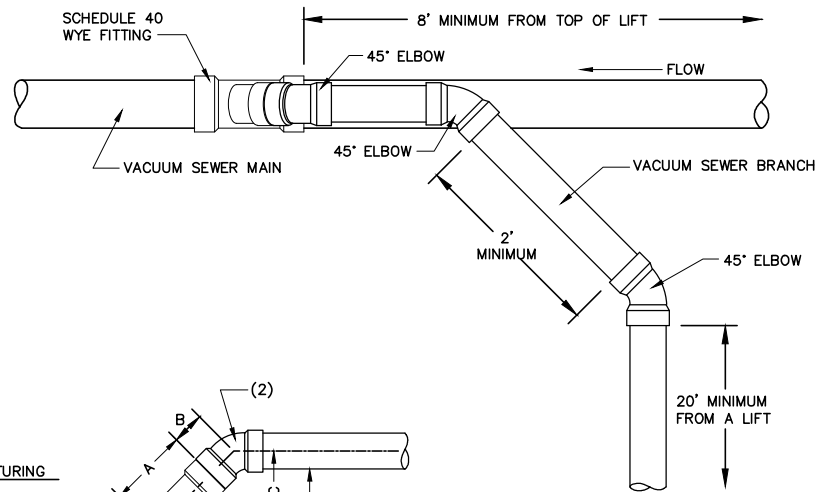

ALTERNATE VACUUM BRANCH TO MAIN LINE CONNECTION

SCALE: N.T.S.

STATEMENT OF USE
THIS DOCUMENT AND ANY ILLUSTRATIONS HEREON ARE PROVIDED AS STANDARD CONSTRUCTION DETAILS WITHIN HOOPER CITY. DEVIATION FROM THIS DOCUMENT REQUIRES APPROVAL OF HOOPER CITY. HOOPER CITY CORPORATION CAN NOT BE HELD LIABLE FOR MISUSE OR CHANGES REGARDING THIS DOCUMENT.

REVISION

NO.	DESCRIPTION	BY	APR.	DATE



VACUUM SEWER DETAILS

HOOPER CITY
DEVELOPMENT STANDARDS

STANDARD DRAWING NUMBER: 19E

CAD DWG: VALVE_PIT 2
PLOT SCALE: 1 = 48
DRAWN BY: JDM
DESIGN BY: TLA
CHECKED BY: TLA
ADOPTED DATE: JUN 2005

NOTE:
 CULINARY WATER MAINS AND SERVICE CROSSINGS SHOULD MAINTAIN AN 18 INCH MINIMUM VERTICAL SEPARATION WHERE EVER POSSIBLE. IN AREAS WHERE THE CULINARY WATER LINES ARE LESS THAN 18 INCH VERTICAL, CONCRETE ENCASEMENT IS REQUIRED AS SHOWN IN THIS DETAIL. ALL OTHER UTILITIES REQUIRE A 12 INCH MINIMUM VERTICAL SEPARATION. ANY UTILITY LOOPS MUST BE APPROVED BY THE CITY.

NOTE:
 IN SITUATIONS WHERE OTHER UTILITIES MAY BE 1 FT. OR LESS OF NEW VACUUM MAIN, THIS DETAIL APPLIES.

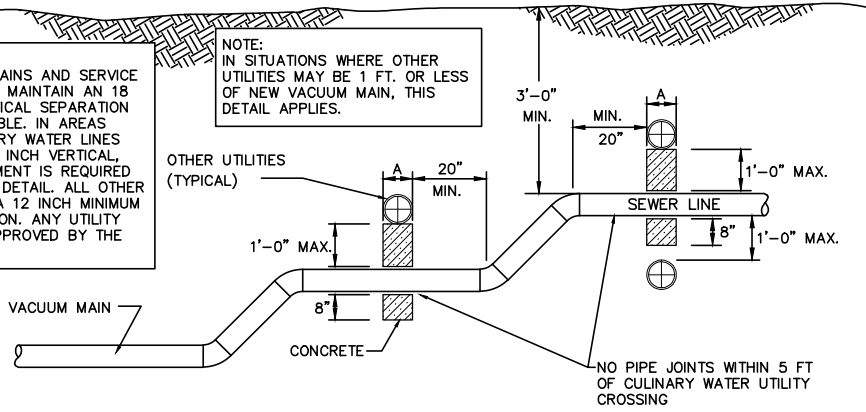

TYPICAL UTILITY CROSSING
 SCALE: N.T.S.

A: WIDTH OF CONCRETE TO MATCH WIDTH OF UTILITY PIPE TO CROSS.

DIVISION VALVE SUPPORT INFORMATION

VALVE SIZE	MIN. SUPPORT SIZE
4"	1" THICK X 1.75' SQUARE
6"	1" THICK X 2.25' SQUARE
8"	1" THICK X 3.00' SQUARE
10"	1" THICK X 3.50' SQUARE

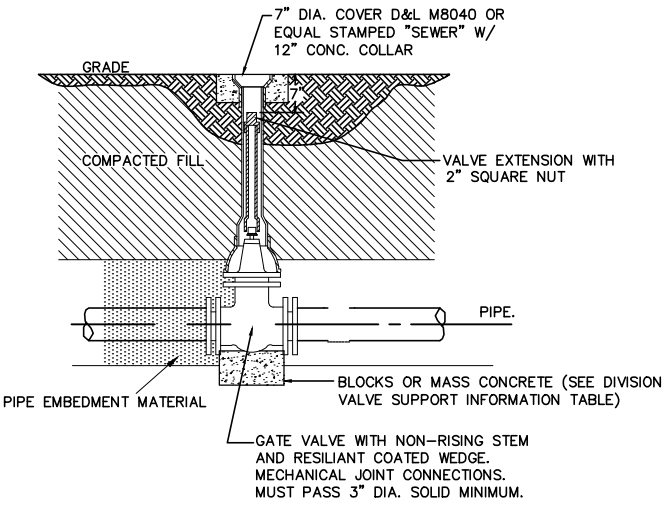

DIVISION VALVE
 SCALE: N.T.S.

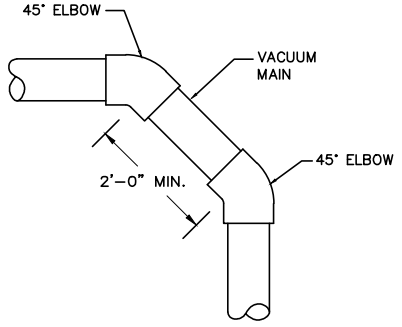

CHANGE IN DIRECTION
 SCALE: N.T.S.

STATEMENT OF USE

THIS DOCUMENT AND ANY ILLUSTRATIONS HEREON ARE PROVIDED AS STANDARD CONSTRUCTION DETAILS WITHIN HOOPER CITY. DEVIATION FROM THIS DOCUMENT REQUIRES APPROVAL OF HOOPER CITY. HOOPER CITY CORPORATION CAN NOT BE HELD LIABLE FOR MISUSE OR CHANGES REGARDING THIS DOCUMENT.

REVISION

NO.	DESCRIPTION	BY	APR.	DATE



VACUUM SEWER DETAILS

HOOPER CITY
 DEVELOPMENT STANDARDS

STANDARD DRAWING NUMBER: **19F**
 CAD DWG: VALVE_PIT 2
 PLOT SCALE: 1 = 48
 DRAWN BY: JDM
 DESIGN BY: TLA
 CHECKED BY: TLA
 ADOPTED DATE: JUN 2005

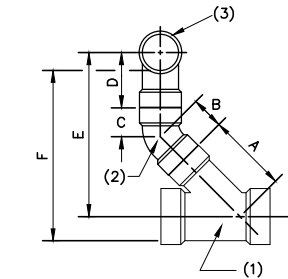
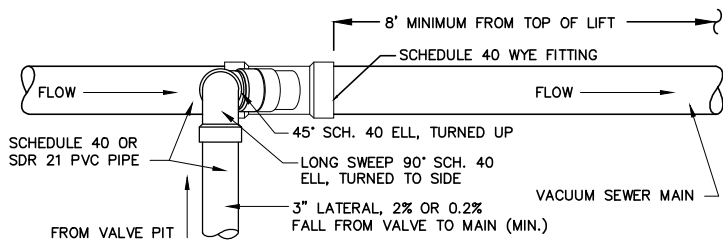

DIMENSIONS BASED ON SPEARS MANUFACTURING

- (1) 45 DEG WYE, SOCKET x SOCKET x SOCKET
- (2) 45 DEG ELL, SOCKET x SOCKET
- (3) 90 DEG ELL, SOCKET x SOCKET

WYE SIZE	A	B	C	D	E	F - INVERT
4 x 4 x 3	9 1/4"	3 1/16"	3 1/16"	3 25/32"	15.55"	1.31'
6 x 6 x 3	10 1/2"	3 1/16"	3 1/16"	3 25/32"	16.43"	1.38'
8 x 8 x 3	13"	3 1/16"	3 1/16"	3 25/32"	18.20"	1.53'
10 x 10 x 3	14 3/8"	3 1/16"	3 1/16"	3 25/32"	19.17"	1.62'

ALTERNATE VACUUM SERVICE CONNECTION TO MAIN SCALE: N.T.S.

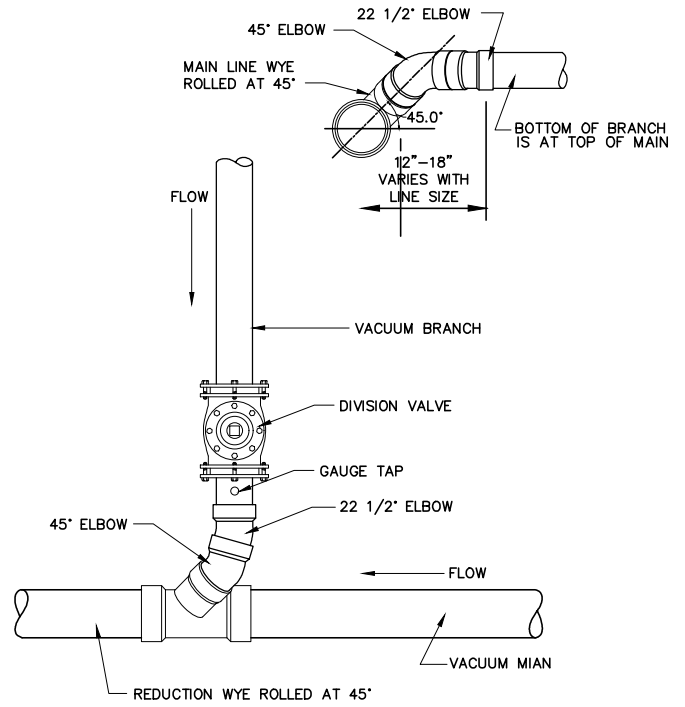

PREFERRED VACUUM BRANCH TO MAIN LINE CONNECTION SCALE: N.T.S.

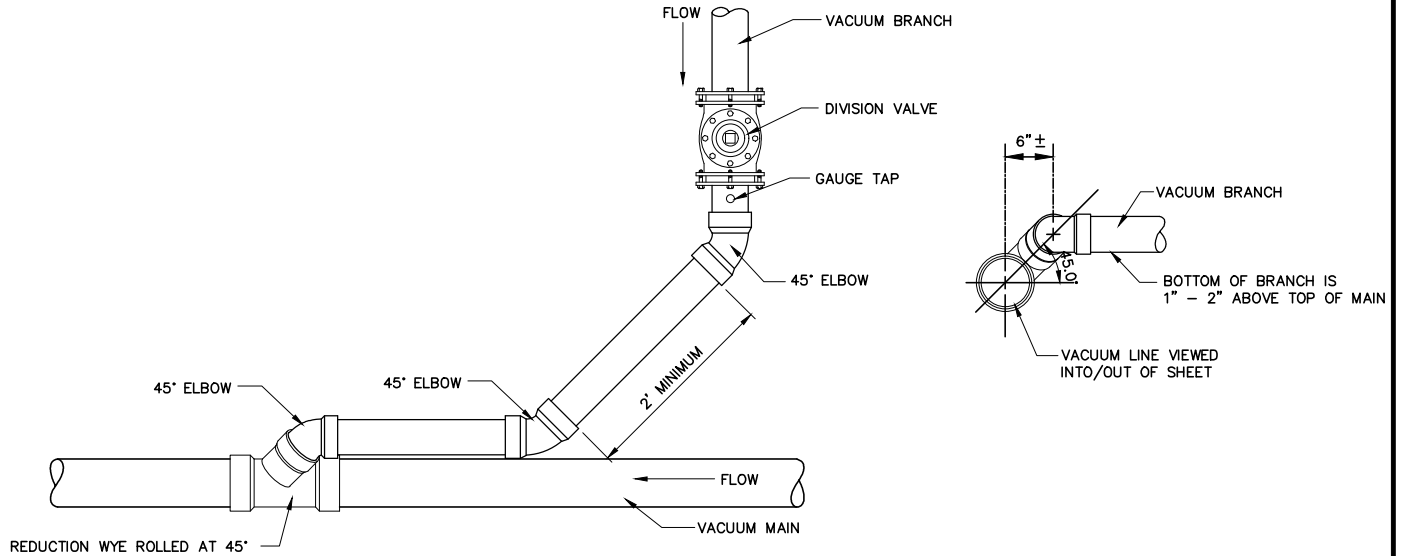

ALTERNATE VACUUM BRANCH TO MAIN LINE CONNECTION SCALE: N.T.S.

STATEMENT OF USE

THIS DOCUMENT AND ANY ILLUSTRATIONS HEREON ARE PROVIDED AS STANDARD CONSTRUCTION DETAILS WITHIN HOOPER CITY. DEVIATION FROM THIS DOCUMENT REQUIRES APPROVAL OF HOOPER CITY. HOOPER CITY CORPORATION CAN NOT BE HELD LIABLE FOR MISUSE OR CHANGES REGARDING THIS DOCUMENT.

REVISION

NO.	DESCRIPTION	BY	APR.	DATE



VALVE SEWER DETAIL

HOOPER CITY DEVELOPMENT STANDARDS

STANDARD DRAWING NUMBER:	19G
CAD DWG:	VALVE PIT 3
PLOT SCALE:	1 = 48
DRAWN BY:	JDM
DESIGN BY:	TLA
CHECKED BY:	TLA
ADOPTED DATE:	JUN 2005

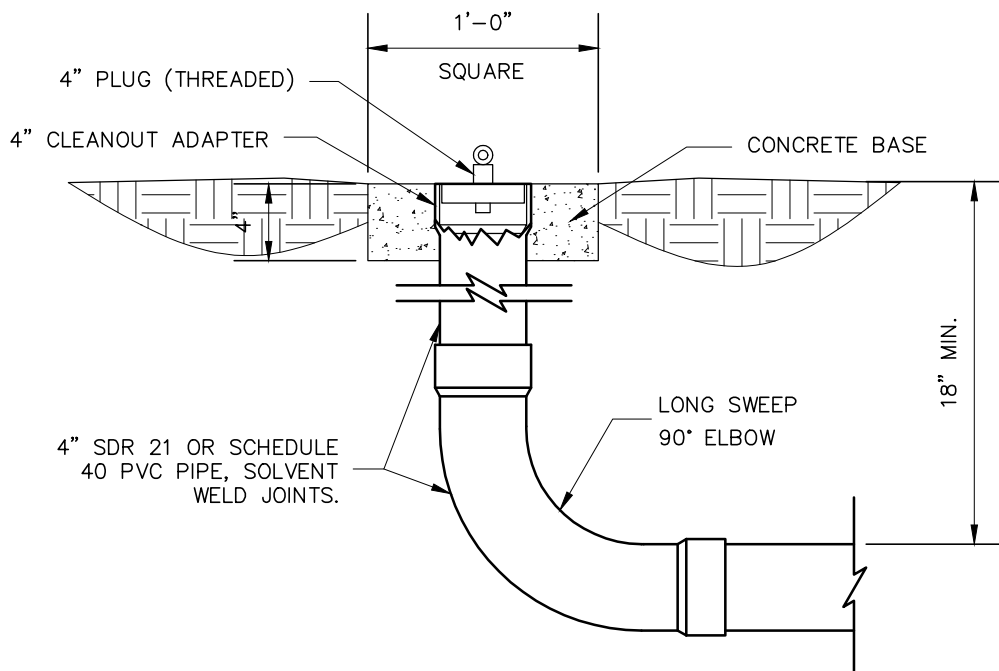

RV SANITARY SEWER DUMP

SCALE: N.T.S.

STATEMENT OF USE

THIS DOCUMENT AND ANY ILLUSTRATIONS HEREON ARE PROVIDED AS STANDARD CONSTRUCTION DETAILS WITHIN HOOPER CITY. DEVIATION FROM THIS DOCUMENT REQUIRES APPROVAL OF HOOPER CITY. HOOPER CITY CORPORATION CAN NOT BE HELD LIABLE FOR MISUSE OR CHANGES REGARDING THIS DOCUMENT.

REVISION

NO.	DESCRIPTION	BY	APR.	DATE
▲				
▲				
▲				



RV SANITARY
SEWER DUMP

HOOPER CITY
DEVELOPMENT STANDARDS

STANDARD
DRAWING
NUMBER: **20**

CAD DWG: RV_SAN_SEWER
PLOT SCALE: 1 = 1
DRAWN BY: KEF
DESIGN BY: TLA
CHECKED BY: TLA
ADOPTED DATE: JUL 2006

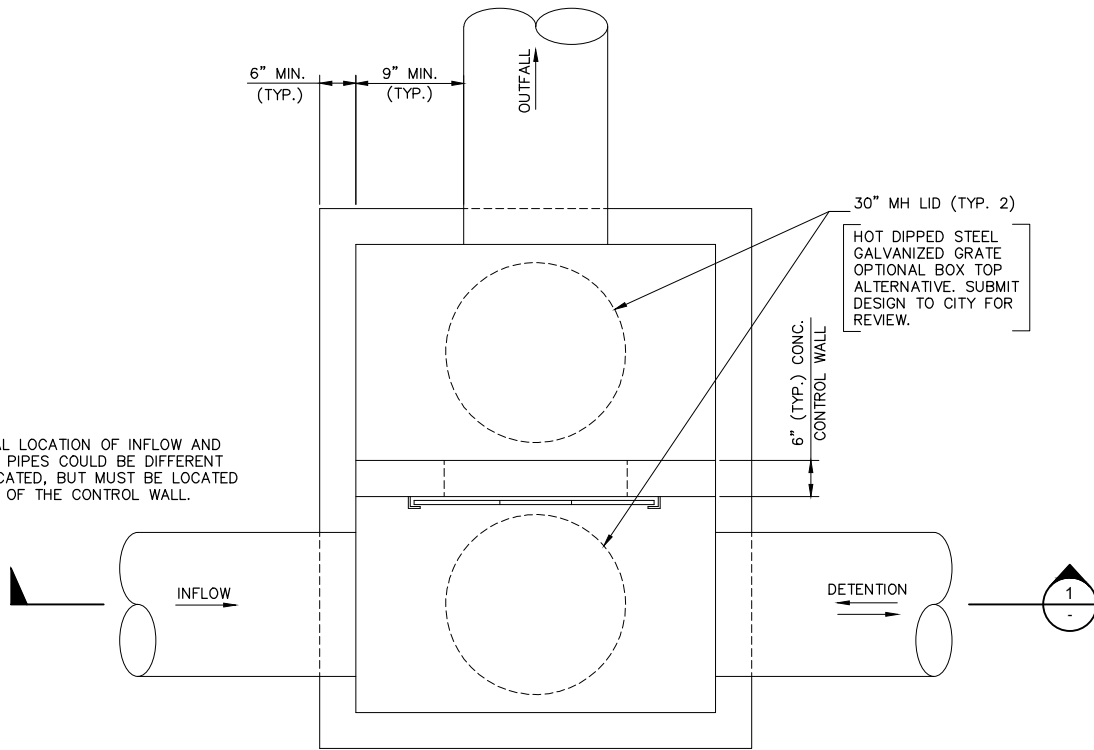

NOTE:
HORIZONTAL LOCATION OF INFLOW AND DETENTION PIPES COULD BE DIFFERENT THAN INDICATED, BUT MUST BE LOCATED UPSTREAM OF THE CONTROL WALL.

STANDARD CONTROL BOX PLAN VIEW

SCALE: N.T.S.

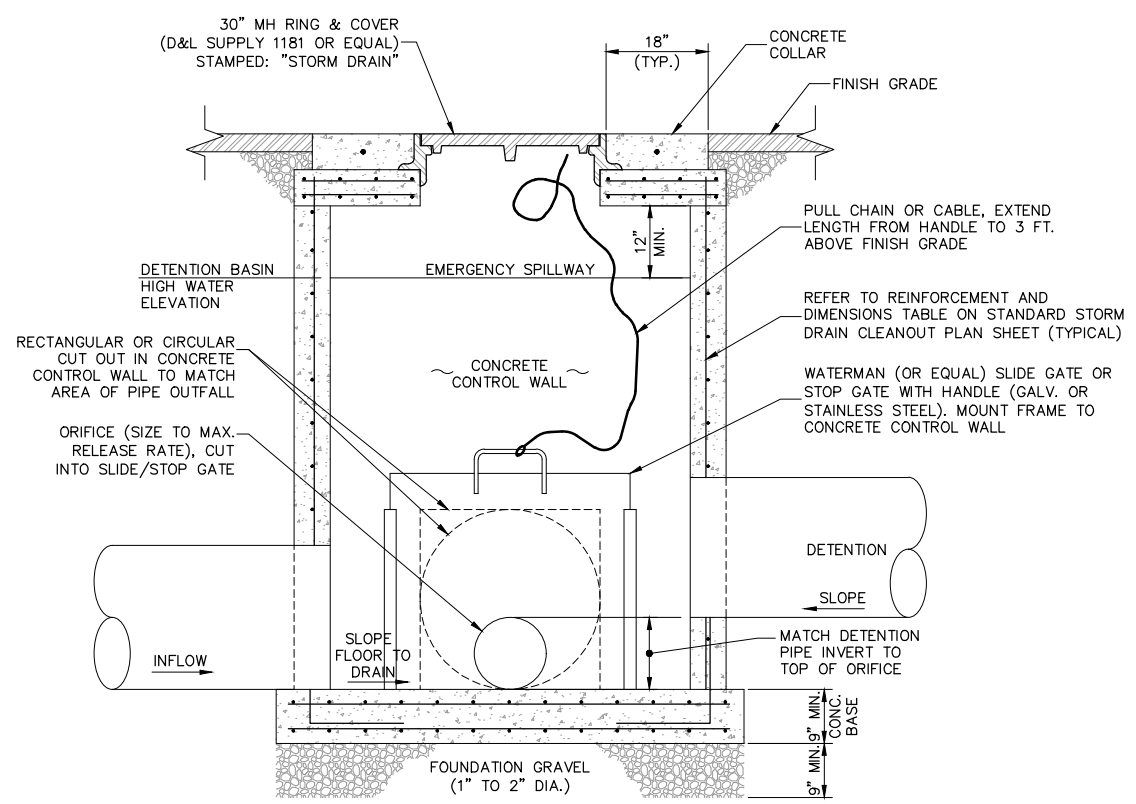

SECTION 1

SCALE: N.T.S.

STATEMENT OF USE

THIS DOCUMENT AND ANY ILLUSTRATIONS HEREON ARE PROVIDED AS STANDARD CONSTRUCTION DETAILS WITHIN HOOPER CITY. DEVIATION FROM THIS DOCUMENT REQUIRES APPROVAL OF HOOPER CITY. HOOPER CITY CORPORATION CAN NOT BE HELD LIABLE FOR MISUSE OR CHANGES REGARDING THIS DOCUMENT.

REVISION			
NO.	DESCRIPTION	BY	APR. DATE



STANDARD STORM DRAIN CONTROL BOX

HOOPER CITY DEVELOPMENT STANDARDS

STANDARD DRAWING NUMBER: **21**

CAD DWG: SD_CONTROL_BOX

PLOT SCALE: 1 = 96

DRAWN BY: JDM

DESIGN BY: RCW

CHECKED BY: TLA

ADOPTED DATE: MAY 2010

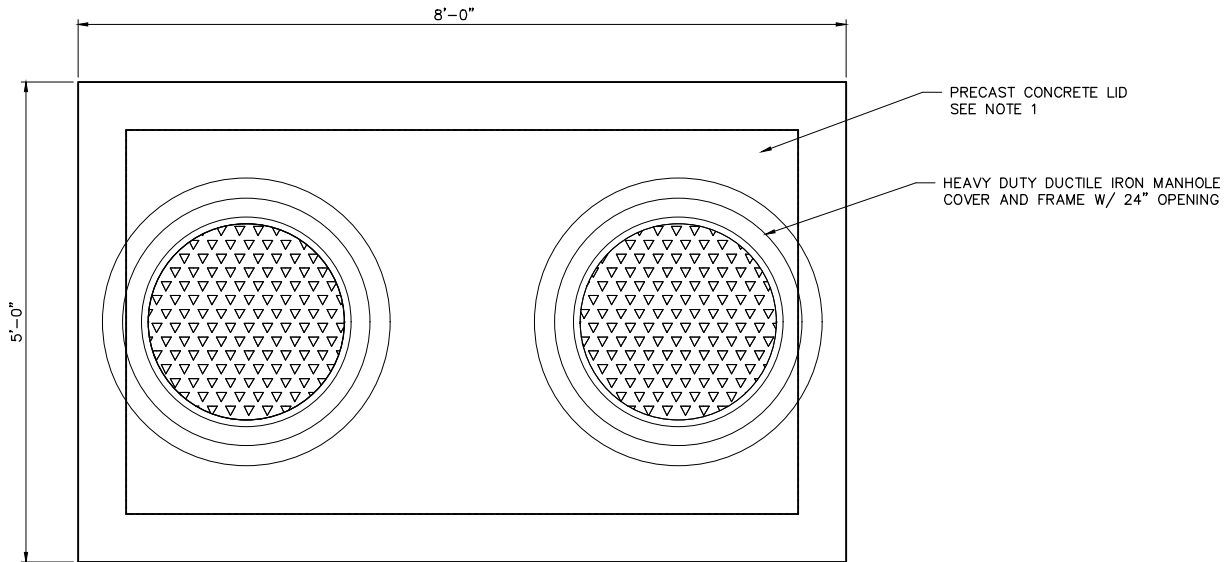

PLAN VIEW

SCALE: N.T.S.

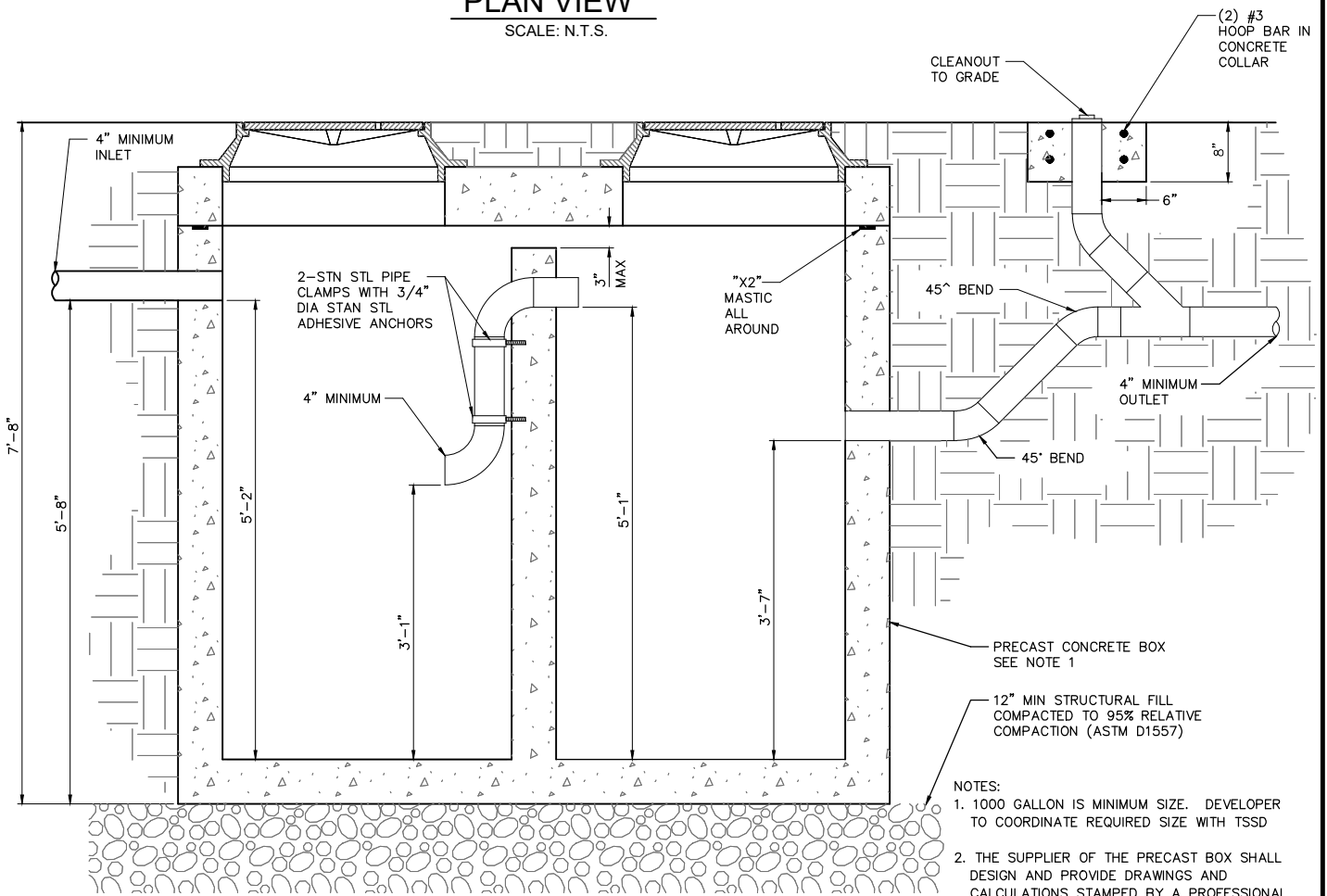

SECTION VIEW

SCALE: N.T.S.

- NOTES:
1. 1000 GALLON IS MINIMUM SIZE. DEVELOPER TO COORDINATE REQUIRED SIZE WITH TSSD
 2. THE SUPPLIER OF THE PRECAST BOX SHALL DESIGN AND PROVIDE DRAWINGS AND CALCULATIONS STAMPED BY A PROFESSIONAL ENGINEER REGISTERED IN THE STATE OF UTAH TO THE CITY ENGINEER FOR APPROVAL.
 3. SUPPLIER SHALL COORDINATE WITH OWNER THE SIZE AND LOCATION OF ALL PIPE PENETRATIONS PRIOR TO FABRICATION
 4. NO SANITARY SEWER THROUGH TRAP
 5. OTHER MANUFACTURER'S DIMENSIONS MAY VARY

STATEMENT OF USE

THIS DOCUMENT AND ANY ILLUSTRATIONS HEREON ARE PROVIDED AS STANDARD CONSTRUCTION DETAILS WITHIN HOOPER CITY. DEVIATION FROM THIS DOCUMENT REQUIRES APPROVAL OF HOOPER CITY. HOOPER CITY CORPORATION CAN NOT BE HELD LIABLE FOR MISUSE OR CHANGES REGARDING THIS DOCUMENT

REVISION

NO.	DESCRIPTION	BY	APR.	DATE



**TYPICAL GREASE TRAP
1000 GALLON CAPACITY**

**HOOPER CITY
DEVELOPMENT STANDARDS**

STANDARD DRAWING NUMBER: **22**

CAD DWG: GREASE_TRAP
PLOT SCALE: 1 = 96
DRAWN BY: JDM
DESIGN BY: RCW
CHECKED BY: TLA
ADOPTED DATE: MAY 2010

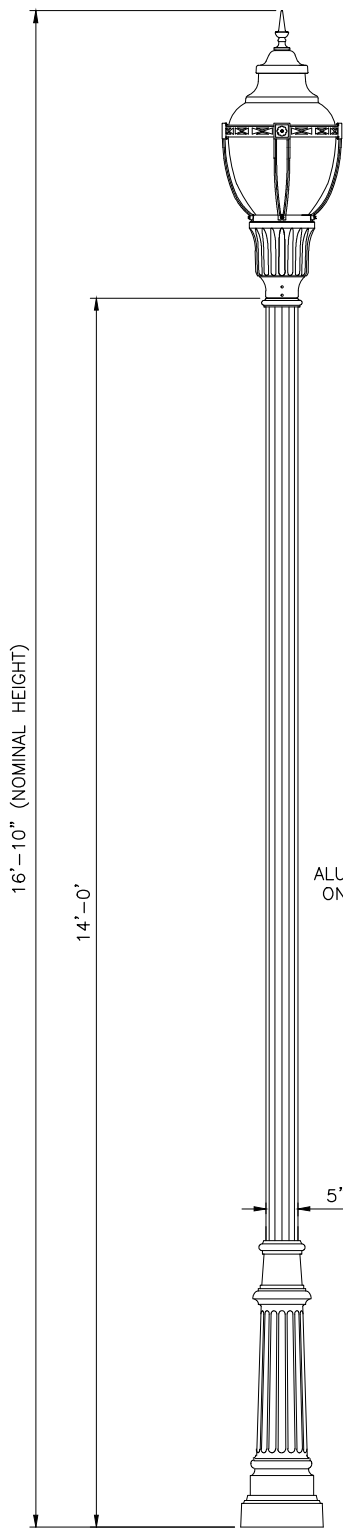

WASHINGTON POSTLITE DETAIL
HOLOPHANE CATALOG #WFCL2035H030KASBKL3SP7PCLLL25

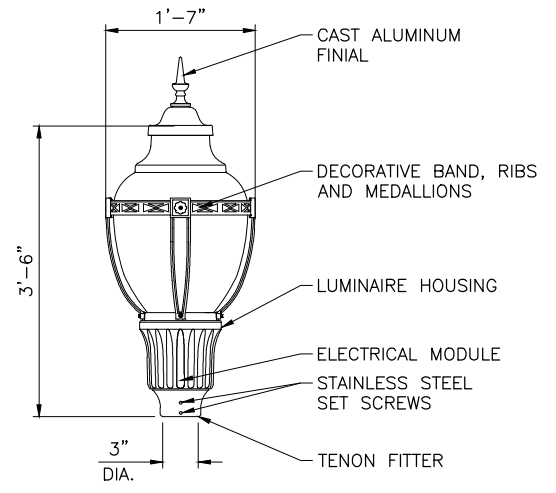

LUMINAIRE DETAIL

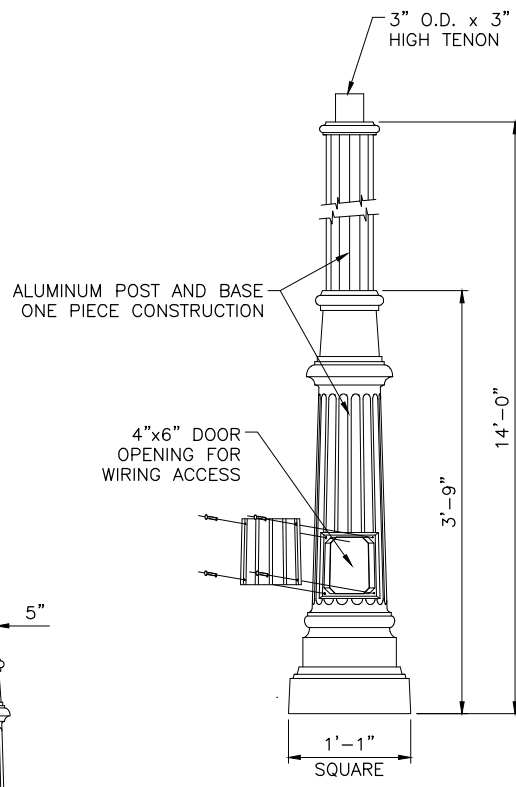

POST DETAIL
CATALOG #SMA14F5J13PO7LABBK

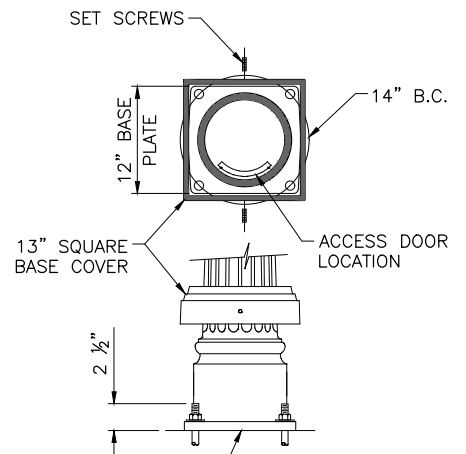

ANCHORAGE DETAIL

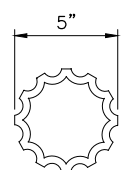

5" DIA. FLUTED SHAFT CROSS SECTION

STATEMENT OF USE
THIS DOCUMENT AND ANY ILLUSTRATIONS HEREON ARE PROVIDED AS STANDARD CONSTRUCTION DETAILS WITHIN HOOPER CITY. DEVIATION FROM THIS DOCUMENT REQUIRES APPROVAL OF HOOPER CITY. HOOPER CITY CORPORATION CAN NOT BE HELD LIABLE FOR MISUSE OR CHANGES REGARDING THIS DOCUMENT.

REVISION			
NO.	DESCRIPTION	BY	APR. DATE



**WASHINGTON POSTLIGHT
TYPE 1 LED STREET LIGHT**

HOOPER CITY
DEVELOPMENT STANDARDS

STANDARD DRAWING NUMBER: **23A**

CAD DWG:
PLOT SCALE: 1 = 12
DRAWN BY: JDM
DESIGN BY: TLA
CHECKED BY: TLA
ADOPTED DATE:

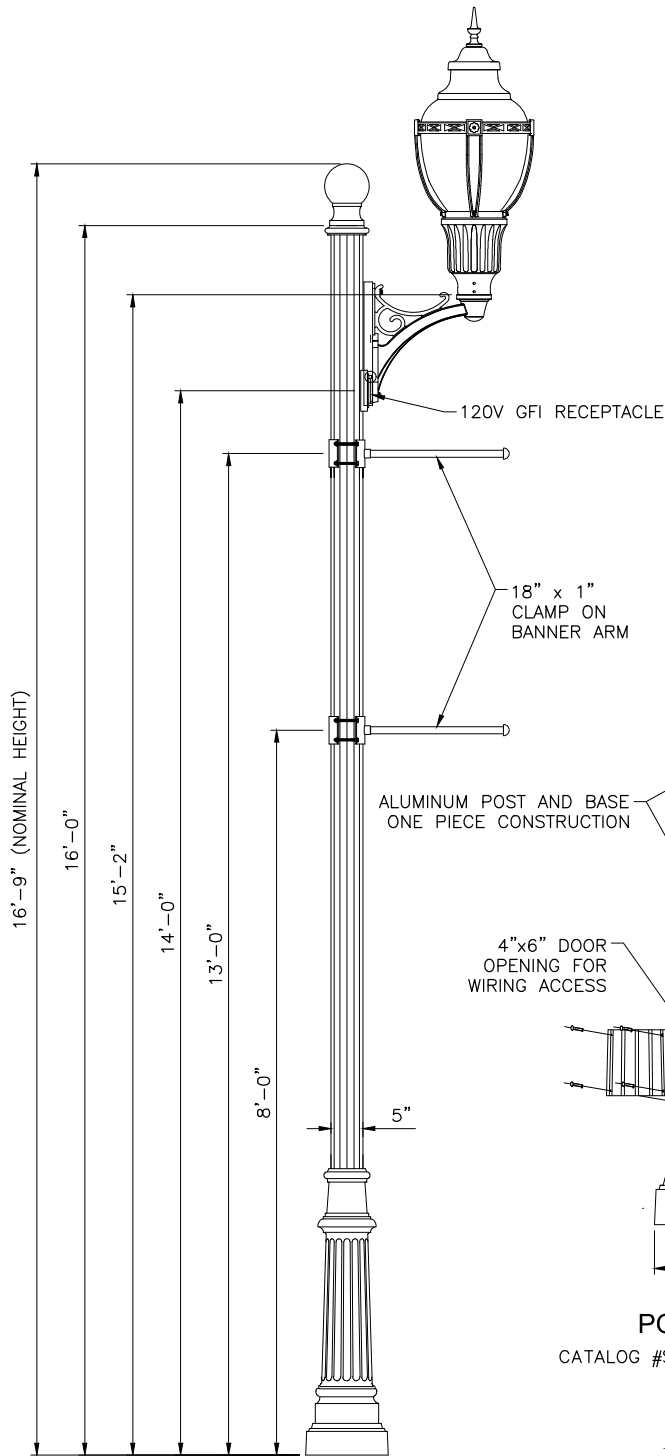

WASHINGTON POSTLITE DETAIL
 HOLOPHANE CATALOG #WFCL2070HO40KASBKL3P7PCLLL25
 FINIAL: #BFCABKH
 ARM: #AWBCABSCROLLH

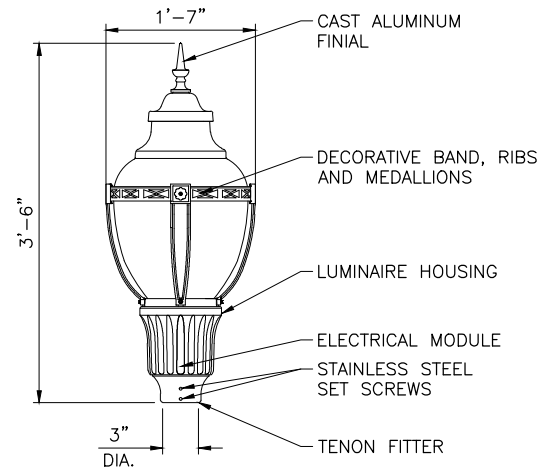

LUMINAIRE DETAIL

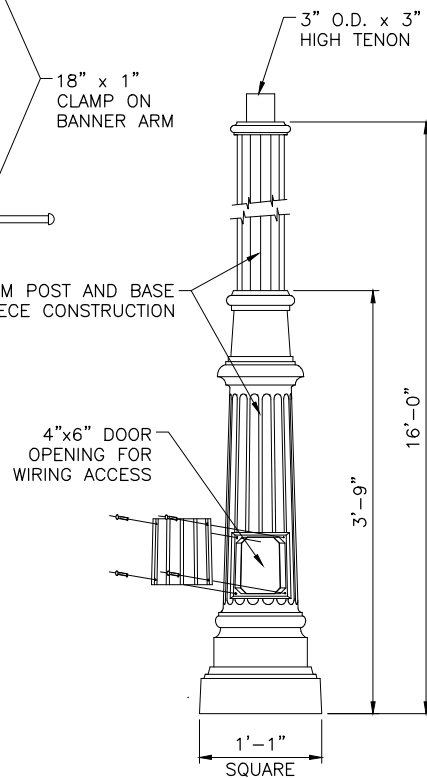

POST DETAIL
 CATALOG #SMA16F5J13P07LABBK

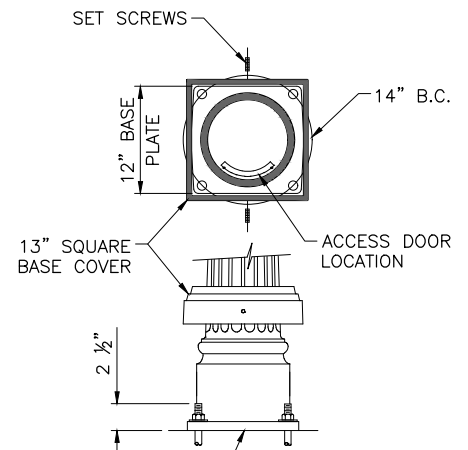

SEE CONCRETE FOUNDATION DETAILS ON STANDARD DRAWING #23C

ANCHORAGE DETAIL

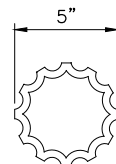

5" DIA. FLUTED SHAFT CROSS SECTION

STATEMENT OF USE

THIS DOCUMENT AND ANY ILLUSTRATIONS HEREON ARE PROVIDED AS STANDARD CONSTRUCTION DETAILS WITHIN HOOPER CITY. DEVIATION FROM THIS DOCUMENT REQUIRES APPROVAL OF HOOPER CITY. HOOPER CITY CORPORATION CAN NOT BE HELD LIABLE FOR MISUSE OR CHANGES REGARDING THIS DOCUMENT.

REVISION

NO.	DESCRIPTION	BY	APR.	DATE



**WASHINGTON POSTLIGHT
 TYPE 2 LED STREET LIGHT**

**HOOPER CITY
 DEVELOPMENT STANDARDS**

STANDARD DRAWING NUMBER: **23B**

CAD DWG:	
PLOT SCALE:	1 = 12
DRAWN BY:	JDM
DESIGN BY:	TLA
CHECKED BY:	TLA
ADOPTED DATE:	

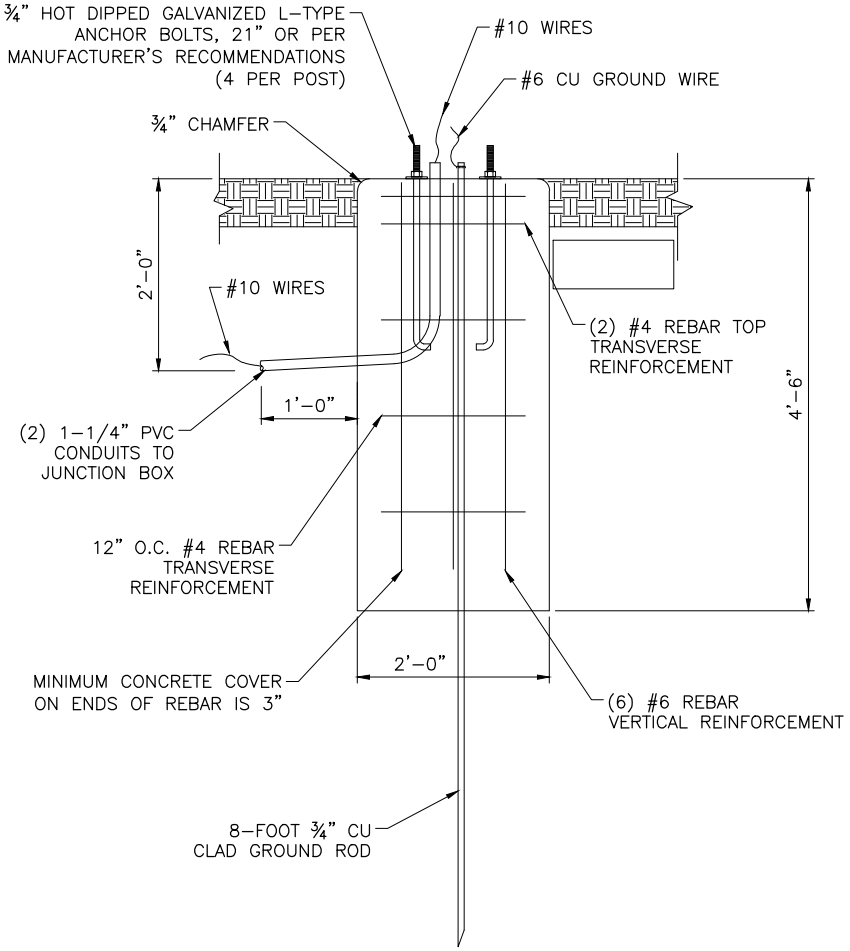
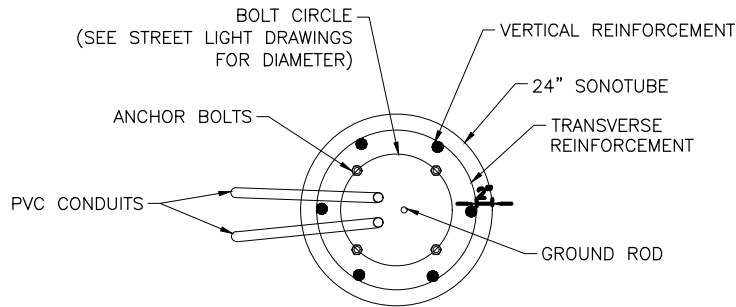

NOTE:
 (1) GROUND ROD AND PLASTIC CONDUITS MUST BE LOCATED WITHIN A 3" RADIUS FROM THE CENTER OF BOLT CIRCLE.
 (2) IN-LINE WATERTIGHT FUSE HOLDERS REQUIRED AT CONNECTION POINT IN BASE OF LIGHT. LITTLEFUSE #WPB1 OR EQUAL.

PLACE JUNCTION BOX BETWEEN 4' AND 10' FROM THE POWER SOURCE AND NEAR THE BASE OF EACH POLE

HDPE CARSON JUNCTION BOX
 BODY MODEL 1419-12 (GREEN)
 COVER MODEL 1419-3B (FLUSH BOLT DOWN) WITH PENTAGON HEAD BOLT
 COVER LOGO "STREET LIGHTING" OR "ELECTRICAL"

FUSE MOLDED PLUG CONNECTORS. 10 AMP FOR EACH PHASE

CONCRETE FOUNDATION

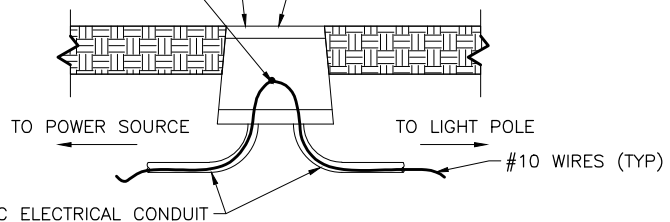

1-1/4" PVC ELECTRICAL CONDUIT
 (TWO CONDUITS FOR STREET LIGHTS A POWER RECEPTACLE;
 ONE CONDUIT FOR STREET LIGHTS WITHOUT POWER RECEPTACLES)

STATEMENT OF USE
 THIS DOCUMENT AND ANY ILLUSTRATIONS HEREON ARE PROVIDED AS STANDARD CONSTRUCTION DETAILS WITHIN HOOPER CITY. DEVIATION FROM THIS DOCUMENT REQUIRES APPROVAL OF HOOPER CITY. HOOPER CITY CORPORATION CAN NOT BE HELD LIABLE FOR MISUSE OR CHANGES REGARDING THIS DOCUMENT.

REVISION				
NO.	DESCRIPTION	BY	APR.	DATE



FOUNDATION AND JUCTION BOX FOR STREET LIGHTS

HOOPER CITY
 DEVELOPMENT STANDARDS

STANDARD DRAWING NUMBER:	23C
CAD DWG:	
PLOT SCALE:	1 = 12
DRAWN BY:	JDM
DESIGN BY:	TLA
CHECKED BY:	TLA
ADOPTED DATE:	

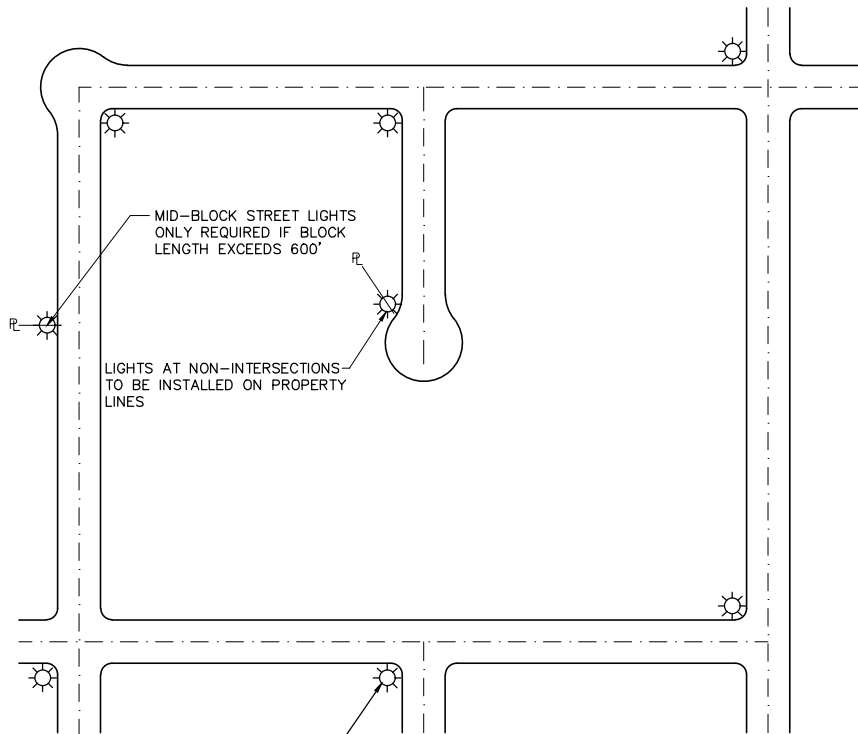

LIGHT TO BE INSTALLED ON OPPOSITE CORNER OF STOP SIGN UNLESS OTHERWISE DETERMINED BY THE CITY ENGINEER OR PUBLIC WORKS DIRECTOR

DEVELOPERS TO INSTALL 2" PVC CONDUIT AND PULL TAPE FROM POWER SOURCE TO JUNCTION BOX AND INSTALL THE JUNCTION BOX

CITY TO COORDINATE THE INSTALLATION OF LIGHT POST AND POWER TO THE LIGHT WITH CITY CONTRACTOR

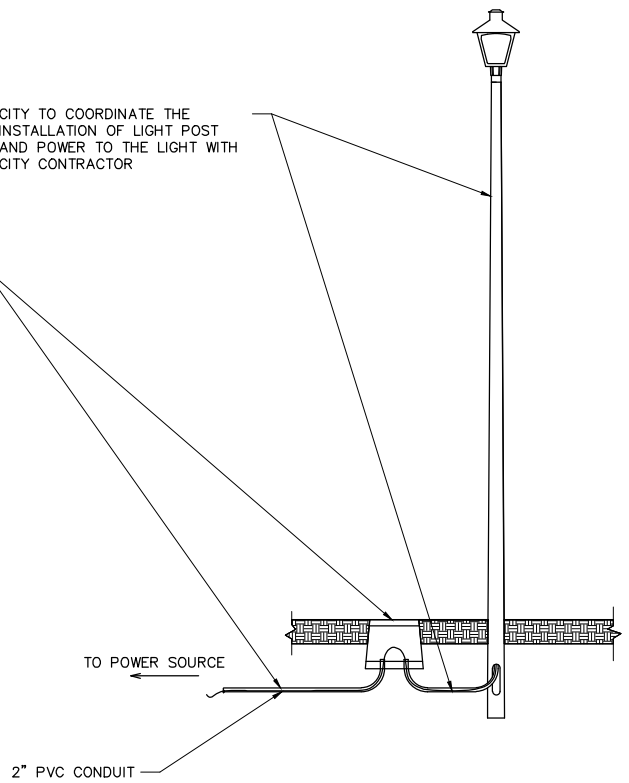

STATEMENT OF USE

THIS DOCUMENT AND ANY ILLUSTRATIONS HEREON ARE PROVIDED AS STANDARD CONSTRUCTION DETAILS WITHIN HOOPER CITY. DEVIATION FROM THIS DOCUMENT REQUIRES APPROVAL OF HOOPER CITY. HOOPER CITY CORPORATION CAN NOT BE HELD LIABLE FOR MISUSE OR CHANGES REGARDING THIS DOCUMENT.

REVISION

NO.	DESCRIPTION	BY	APR.	DATE
▲				
▲				
▲				



STANDARD STREET LIGHTING LOCATIONS

HOOPER CITY
DEVELOPMENT STANDARDS

STANDARD DRAWING NUMBER: **23D**

CAD DWG:
PLOT SCALE: 1 = 12
DRAWN BY: JDM
DESIGN BY: TLA
CHECKED BY: TLA
ADOPTED DATE:

NOTES:

1. THIS DETAIL APPLIES WHEN REQUIRED BY PUBLIC WORKS FOR TRANSITION FROM PIPED DITCH TO OPEN CHANNEL.
2. STRUCTURAL DESIGN SHALL BE COMPLETED BY THE ENGINEER-OF-RECORD FOR THE PROJECT. DETAILS SHALL BE INCLUDED IN PROJECT DRAWINGS.
3. THE CONCRETE SPLASH PAD IS OPTIONAL UNLESS REQUIRED BY PUBLIC WORKS.
4. DESIGNED HEIGHT OF HEADWALL AND SLOPE OF WINGWALLS MUST CONSIDER MOTORIST SAFETY IF STRUCTURE IS ADJACENT TO A ROADWAY

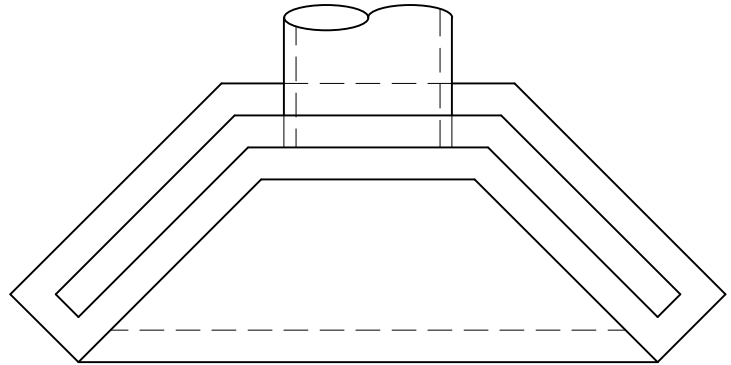

PLAN VIEW
SCALE: N.T.S.

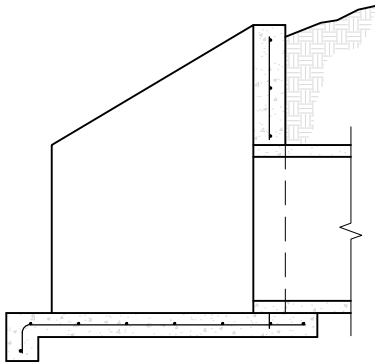

SECTION 1
SCALE: N.T.S.

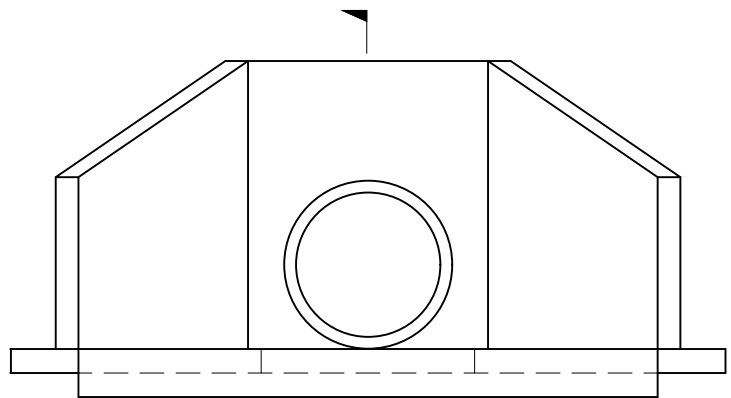

FRONT VIEW
SCALE: N.T.S.



STATEMENT OF USE			
THIS DOCUMENT AND ANY ILLUSTRATIONS HEREON ARE PROVIDED AS STANDARD CONSTRUCTION DETAILS WITHIN HOOPER CITY. DEVIATION FROM THIS DOCUMENT REQUIRES APPROVAL OF HOOPER CITY. HOOPER CITY CORPORATION CAN NOT BE HELD LIABLE FOR MISUSE OR CHANGES REGARDING THIS DOCUMENT.			
REVISION			
NO.	DESCRIPTION	BY	APR. DATE
▲			
▲			
▲			



**CONCRETE HEADWALL
WITH WINGWALLS**

HOOPER CITY
DEVELOPMENT STANDARDS

STANDARD DRAWING NUMBER:	24
CAD DWG: WING WALL	
PLOT SCALE:	1 = 1
DRAWN BY:	JDM
DESIGN BY:	TLA
CHECKED BY:	TLA
ADOPTED DATE:	NOV 2005

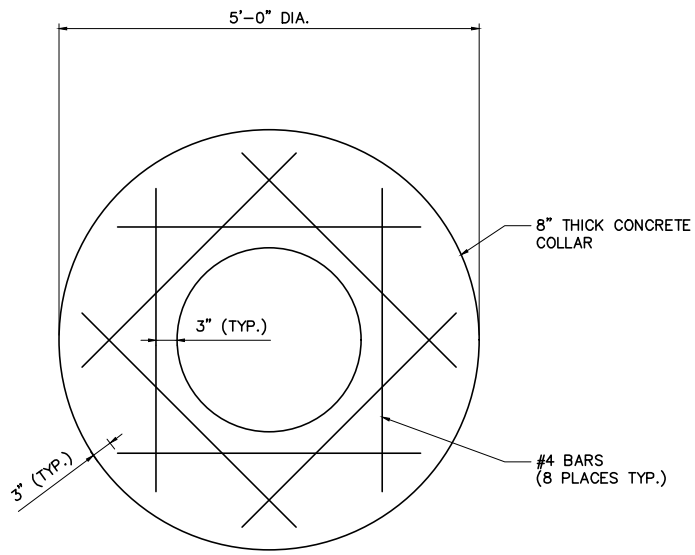

PLAN

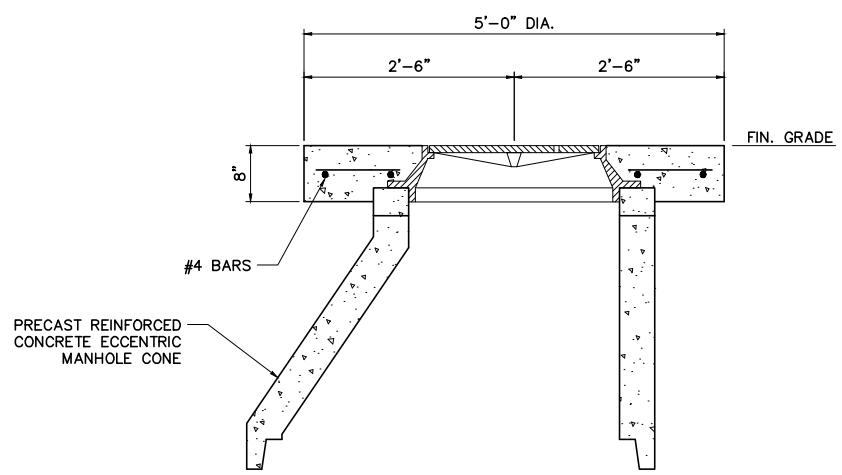

SECTION

NOTE:
USE GRADE RINGS AS NECESSARY TO
ARRIVE AT REQUIRED FINISH GRADE.

STATEMENT OF USE

THIS DOCUMENT AND ANY ILLUSTRATIONS HEREON ARE PROVIDED AS STANDARD CONSTRUCTION DETAILS WITHIN HOOPER CITY. DEVIATION FROM THIS DOCUMENT REQUIRES APPROVAL OF HOOPER CITY. HOOPER CITY CORPORATION CAN NOT BE HELD LIABLE FOR MISUSE OR CHANGES REGARDING THIS DOCUMENT.

REVISION

NO.	DESCRIPTION	BY	APR.	DATE
▲				
▲				
▲				



MANHOLE CONCRETE COLLAR

HOOPER CITY
DEVELOPMENT STANDARDS

STANDARD DRAWING NUMBER: **26A**

CAD DWG:	CONC_COLLAR
PLOT SCALE:	1 = 1
DRAWN BY:	JDM
DESIGN BY:	TLA
CHECKED BY:	TLA
ADOPTED DATE:	NOV 2003

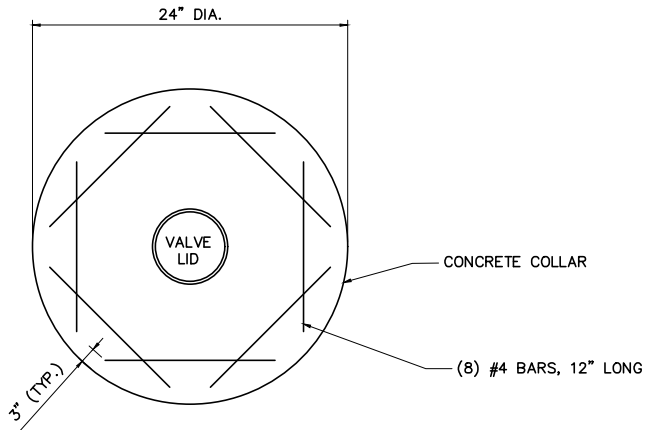

PLAN

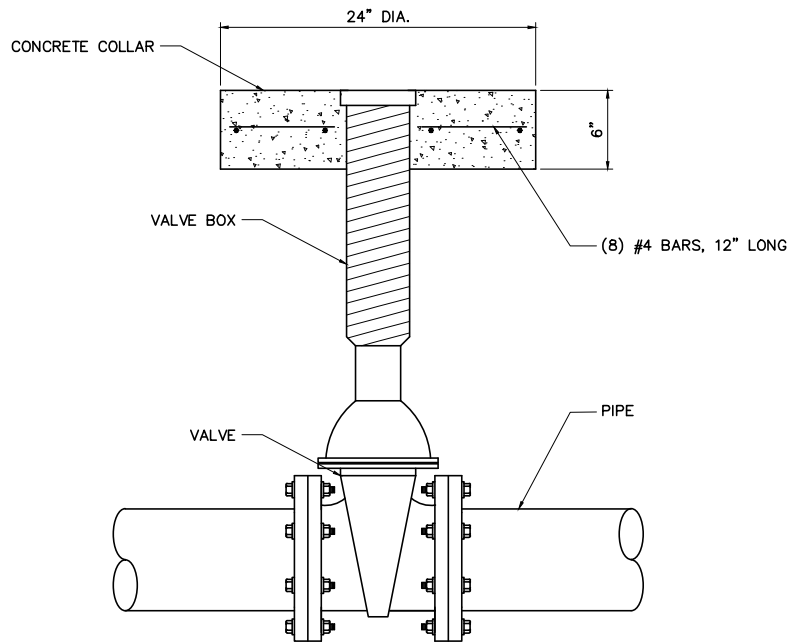

SECTION

NOTE:
COORDINATE CONCRETE COLLAR AND
VALVE BOX LID REQUIREMENTS WITH
INDIVIDUAL UTILITY COMPANIES.

UTILITY	LID	CONCRETE COLLAR	NOTES
HOOPER CITY VACUUM SEWER	ROUND "SEWER"	24" SQUARE	
HOOPER WATER IMPROVEMENT DISTRICT	ROUND "WATER"	COORDINATE	SURVEY MONUMENT REQUIRED
HOOPER IRRIGATION COMPANY	TRIANGULAR "WATER"	24" ROUND	
TAYLOR-WEST WEBER WATER IMPROVEMENT DISTRICT	ROUND "WATER"	COORDINATE	COORDINATE

STATEMENT OF USE

THIS DOCUMENT AND ANY ILLUSTRATIONS HEREON ARE PROVIDED AS STANDARD CONSTRUCTION DETAILS WITHIN HOOPER CITY. DEVIATION FROM THIS DOCUMENT REQUIRES APPROVAL OF HOOPER CITY. HOOPER CITY CORPORATION CAN NOT BE HELD LIABLE FOR MISUSE OR CHANGES REGARDING THIS DOCUMENT.

REVISION

NO.	DESCRIPTION	BY	APR.	DATE



VALVE CONCRETE COLLAR

**HOOPER CITY
DEVELOPMENT STANDARDS**

STANDARD DRAWING NUMBER: **26B**

CAD DWG: CONC_COLLAR
PLOT SCALE: 1 = 1
DRAWN BY: JDM
DESIGN BY: TLA
CHECKED BY: TLA
ADOPTED DATE: NOV 2003

CONSTRUCTION NOTES:

- PUMP STATION MECHANICAL EQUIPMENT SHOWN IS SCHEMATIC. CONTRACTOR IS RESPONSIBLE FOR CORRECT QUANTITIES AND PIPE SPOOL LENGTHS AS REQUIRED FOR A FULLY FUNCTIONAL INSTALLATION. VERIFY ALL DIMENSIONS (BOTH VERTICAL AND HORIZONTAL). VERIFY MANUFACTURERS CONNECTION DETAILS AND INSTALLATION REQUIREMENTS. PROVIDE A DIMENSIONED DRAWING SHOWING ALL VALVES, FITTINGS, PIPE SPOOLS, AND PUMP CONNECTIONS WITH SHOP DRAWING SUBMITTAL. COORDINATE ALL WORK WITH RELATED TRADES TO AVOID CONFLICTS.
- INITIAL FLOAT SWITCH SETTINGS (FIELD ADJUST TO OPTIMIZE PERFORMANCE AS REQUIRED):

ELEVATION (FEET)	CONTROLLER FUNCTION FOR RISING LEVEL	CONTROLLER FUNCTION FOR FALLING LEVEL
XXXX.XX	HIGH WATER ALARM ON	HIGH WATER ALARM OFF
XXXX.XX	LAG PUMP ON	
XXXX.XX	LEAD PUMP ON	
XXXX.XX		BOTH PUMPS OFF AND ALTERNATE LEAD/LAG

- INSTALL PUMP AND ALL RELATED PUMP EQUIPMENT IN STRICT ACCORDANCE WITH THE DRAWINGS, SPECIFICATIONS, AND MANUFACTURERS RECOMMENDATIONS.
- GENERATOR BUILDING AND SITE REQUIREMENTS ARE NOT INCLUDED IN THESE DRAWINGS. REFER TO LIFT STATION SPECIFICATIONS FOR SPECIFIC REQUIREMENTS.
- REFER TO GEOTECH REPORT FOR BACKFILL REQUIREMENTS. IMPORTED BACKFILL MAY BE REQUIRED.
- PROTECT BUILDINGS, FENCES, CURBS, AND SIDEWALKS ADJACENT TO THE SITE, UNLESS NOTED OTHERWISE. DAMAGE BY CONTRACTORS OPERATIONS SHALL BE REPAIRED AT CONTRACTORS EXPENSE.
- UNLESS NOTED OTHERWISE, ALL PIPING AND FITTINGS FROM THE PUMPS THROUGH THE VALVE VAULT SHALL BE DUCTILE IRON CLASS 53 AND HAVE A 2-PART HIGH BUILD COAL TAR EPOXY COATING (40 MIL THICKNESS) ON INTERIOR AND EXTERIOR SURFACES.
- ALL BOLTS, NUTS, WASHERS, FASTENERS, ETC. SHALL BE STAINLESS STEEL, TYPE 304 OR 316.
- INSTALL EXPANSION JOINT MATERIAL BETWEEN CONCRETE STRUCTURES AND ANY CONCRETE SLABS
- NOT ALL FEATURES ARE SHOWN IN BOTH PLAN AND SECTION VIEWS FOR CLARITY.

KEYED NOTES:

- 20HP FLYGT SUBMERSIBLE PUMP MODEL NP3153.185-462 UNLESS OTHERWISE APPROVED BY THE CITY
- 4" PUMP QUICK DISCONNECT DISCHARGE ELBOW AND MOUNTING BASE WITH EPOXY-SET ST.ST. ANCHOR BOLTS, VERIFY SIZE WITH PUMP MFR.
- 6" UNI-FLANGE (MEGA-LUG)
- 6" RESTRAINED FLANGE COUPLING ADAPTER
- 6" DI PIPE SPOOL (FLxPE)
- 6" DI 90° LONG RADIUS ELBOW (FLGxFLG)
- WATERTIGHT WALL PENETRATION, MANHOLE ADAPTER "A-LOK", "KOR-N-SEAL" OR EQUIVALENT. FOR DEPTHS GRATER THAN 15', USE A PENETRATION SEAL THAT IS RATED FOR HIGHER HYDROSTATIC GROUNDWATER PRESSURES SUCH AS "LINK-SEAL".
- DUAL 6" FLEXIBLE SLEEVE-TYPE PIPE COUPLINGS
- 6" DI PIPE SPOOL (PExPE)
- 6" SWING CHECK VALVE (FLGxFLG)
- 6"x6" DI CROSS (FLG)
- VALVE/PIPE SUPPORT, SEE DETAIL
- 6'-0"x6'-0"x6'-6" HIGH PRECAST CONCRETE VALVE VAULT WITH PLASTIC COATED STEPS. 6" MIN. WALL THICKNESS. HS-20 RATED. MODIFY OPENINGS AS REQ'D TO ACCOMMODATE PIPING AND ACCESS HATCH AS SHOWN. COAT EXTERIOR WITH WATERPROOFING TREATMENT.
- 8" PVC C-900 FORCEMAIN
- 8'x10' PRECAST CONCRETE WETWELL HS-20 RATED WITH MONOLITHIC BASE. CHECK BUOYANCY CALC'S TO DETERMINE MIN. BASE THICKNESS AND IF WING IS NEEDED. DESIGN PER GEOTECH REPORT. COAT EXTERIOR WITH WATERPROOF TREATMENT.
- STAINLESS STEEL PUMP REMOVAL SYSTEM, COMPLETE WITH MOUNTING BRACKETS AND INTERMEDIATE SUPPORT BRACES.
- SCREENED VENT, SEE DETAIL
- INLET SEWER. A SINGLE INLET SEWER IS PREFERABLE. TO MULTIPLE INLET SEWERS. MINIMIZE CASCADING FLOW INTO WETWELL. ENTRAINED AIR AND TURBULENCE REDUCES EFFICIENCY OF PUMPS.
- 6" PLUG VALVE WITH HAND WHEEL (FLGxFLG)
- 36"x60" MIN. ALUMINUM DOUBLE LEAF ACCESS DOOR WITH STAINLESS STEEL HARDWARE AND ORANGE SAFETY GRATE - OPENING DIMENSIONS AND DOOR LOCATION SHALL BE IN ACCORDANCE WITH PUMP MANUFACTURERS REQUIREMENTS. HATCH SHALL BE HS-20 TRAFFIC RATED AND WATER-TIGHT. PROVIDE RECESSED, LOCKABLE HASP COVERED WITH HINGED LID FLUSH WITH SURFACE. INSTALL DOOR SUCH THAT ENTRY SYSTEM IS NOT IN CONFLICT WITH DOOR.
- STAINLESS STEEL CABLE SUPPORT BRACKET FOR POWER CABLES AND FLOAT SWITCHES, THE BRACKET IS SHOWN SCHEMATICALLY IN THESE DRAWINGS. THE SUPPORT BRACKET NEEDS TO BE LOCATED SO THE CABLES AND FLOATS ARE EASILY ACCESSIBLE FROM THE ACCESS HATCH. FIELD ADJUST TO AVOID CONFLICTS WITH PUMP REMOVAL AND TO OPTIMIZE FLOAT SWITCH PERFORMANCE.
- 30"x30" MIN. ALUMINUM SINGLE LEAF ACCESS DOOR WITH STAINLESS STEEL HARDWARE. HATCH SHALL BE HS-20 TRAFFIC RATED AND WATER-TIGHT. PROVIDE RECESSED, LOCKABLE HASP COVERED WITH HINGED LID FLUSH WITH SURFACE. INSTALL DOOR SUCH THAT ENTRY SYSTEM IS NOT IN CONFLICT WITH DOOR. PLUMB HATCH RIM DRAIN TO VAULT FLOOR DRAIN.
- STAINLESS STEEL LIFTING CHAIN OR CABLE (MIN. STRENGTH 6,000 LBS.) WITH S.S. CLEVIS FITTING AT EACH END.
- THRUST RESTRAINT PIPE SUPPORT, SEE DETAIL.
- MANHOLE JOINT WITH EXTRUDED BUTYL RUBBER SEAL OR EQUIVALENT. GROUT JOINT INSIDE AND OUT OR VULLCEM 16 JOINT SEALANT CAULKING, TYP.
- CRUSHED AGGREGATE (3/4" MINUS) COMPACTED TO 95% ASTM D-698 OR MODIFIED PROCTOR UNLESS INDICATED OTHERWISE IN GEOTECH REPORT.
- 6" ALUM. LOCKING CAM-LOCK FITTING WITH PRESSURE CAP. EXTEND THROUGH TOP OF VAULT TO 18" ABOVE GRADE.
- INSTALL SLIDE RAILS AND ELECTRICAL CONDUIT FOR FUTURE GRINDER. COORDINATE WITH GRINDER SUPPLIER (JWC ENVIRONMENTAL MUFFIN MONSTER MODEL 30005-0012)
- 2'x2' ALUMINUM ACCESS HATCH FOR FUTURE GRINDER (HS-20 TRAFFIC RATED AND WATER-TIGHT)
- LOCATING WIRE. PROVIDE SUFFICIENT LENGTH FOR WIRE TO BE PULLED TO GROUND SURFACE.
- 4" FLAP GATE
- 8"x6" DI CONCENTRIC REDUCER, (MJxMJ)
- 8" DI BEND (MJxMJ) WITH THRUST BLOCK
- 6"Ø CAST IRON FLOOR DRAIN, P-TRAP, & 4" PVC DRAIN TO WETWELL SLOPED AT 2% MIN.
- ITT FLYGT MIX FLUSH VALVE, ONE PUMP ONLY
- APPLY SPECTRASHIELD LINER (OR APPROVED EQUAL) TO INTERIOR OF WETWELL AFTER ALL JOINTS ARE SEALED AND PIPES ARE INSTALLED.
- GROUT PLUG (WATER-TIGHT)
- PRESSURE GAUGE ASSEMBLY (SEE DETAIL 2 OF M-102)
- 6"x4" CONCENTRIC REDUCER (FLGxFLG)
- 4" UNI-FLANGE (MEGA-LUG)

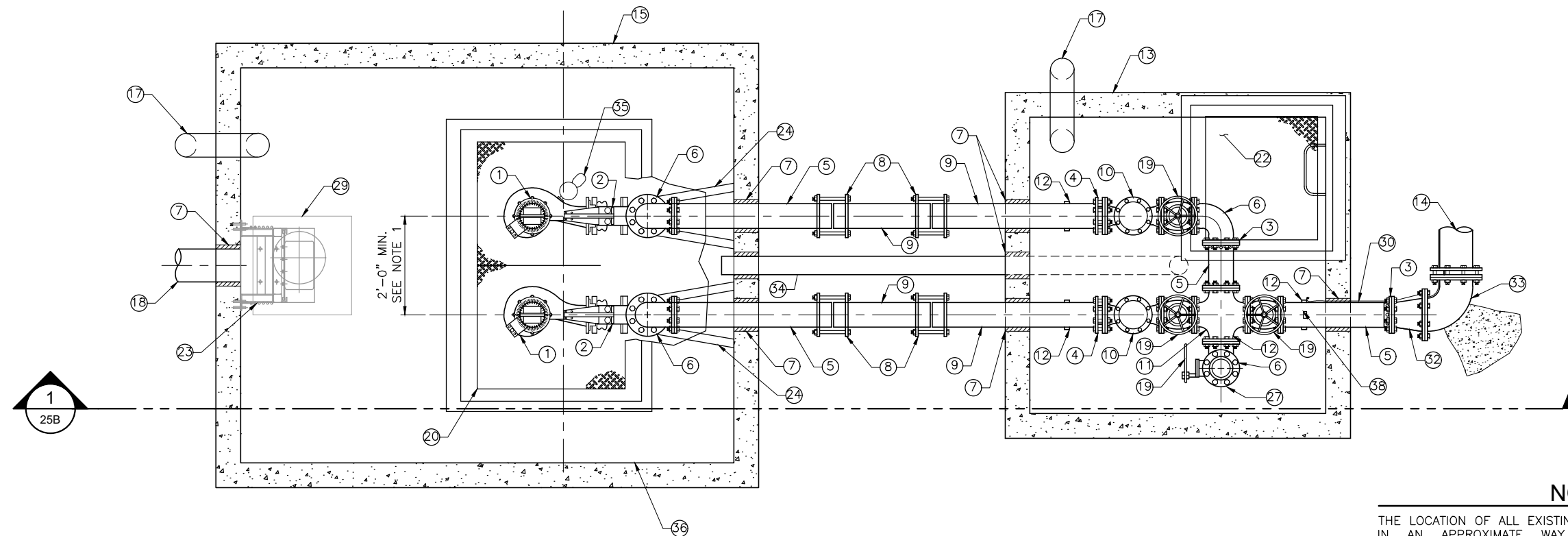

NOTE

THE LOCATION OF ALL EXISTING UNDERGROUND UTILITIES IS SHOWN IN AN APPROXIMATE WAY ONLY. THE CONTRACTOR SHALL DETERMINE THE EXACT LOCATION OF ALL EXISTING UTILITIES BEFORE COMMENCING WORK. HE AGREES TO BE FULLY RESPONSIBLE FOR ANY AND ALL DAMAGES WHICH MIGHT BE OCCASIONED BY HIS FAILURE TO EXACTLY LOCATE AND PRESERVE ANY AND ALL UNDERGROUND UTILITIES

CALL 48 HOURS BEFORE YOU DIG

811



J-U-B ENGINEERS, INC.

J-U-B ENGINEERS, INC.
466 North 900 West
Kaysville, Utah 84037
Phone: 801.547.0393
Fax: 801.547.0397
www.jub.com

PRELIMINARY PLANS

NOT FOR CONSTRUCTION

THIS DOCUMENT AND THE IDEAS AND DESIGNS INCORPORATED HEREIN ARE THE PROPERTY OF J-U-B ENGINEERS, INC. AND IS NOT TO BE USED IN WHOLE OR PART FOR ANY OTHER PROJECT WITHOUT THE EXPRESS WRITTEN AUTHORIZATION OF J-U-B ENGINEERS, INC.

STANDARD LIFT STATION DETAIL
HOOPER CITY

M-101

FILE: LIFT STATION
JUB PROJ. #: 55-14-044
DRAWN BY: ##
DESIGN BY: ##
CHECKED BY: ##
ONE INCH
AT FULL SIZE, IF NOT ONE INCH, SCALE ACCORDINGLY
LAST UPDATED: 1/26/2018
SHEET NUMBER:

27A

Plot Date: 1/26/2018 10:12 AM Plotted By: Jason Miller Date Created: 1/24/2018 File: STANDARDS\CITY STANDARDS\UPDATED STANDARDS\HOOPER-LIFT STATION.DWG

1 LIFT STATION - MECHANICAL PLAN
SCALE: 3/4"=1'

REUSE OF DRAWINGS AND THE IDEAS AND DESIGNS INCORPORATED HEREIN ARE THE PROPERTY OF J-U-B ENGINEERS, INC. AND IS NOT TO BE USED IN WHOLE OR PART FOR ANY OTHER PROJECT WITHOUT THE EXPRESS WRITTEN AUTHORIZATION OF J-U-B ENGINEERS, INC.

NO.	REVISION	DESCRIPTION	BY	APPR.	DATE

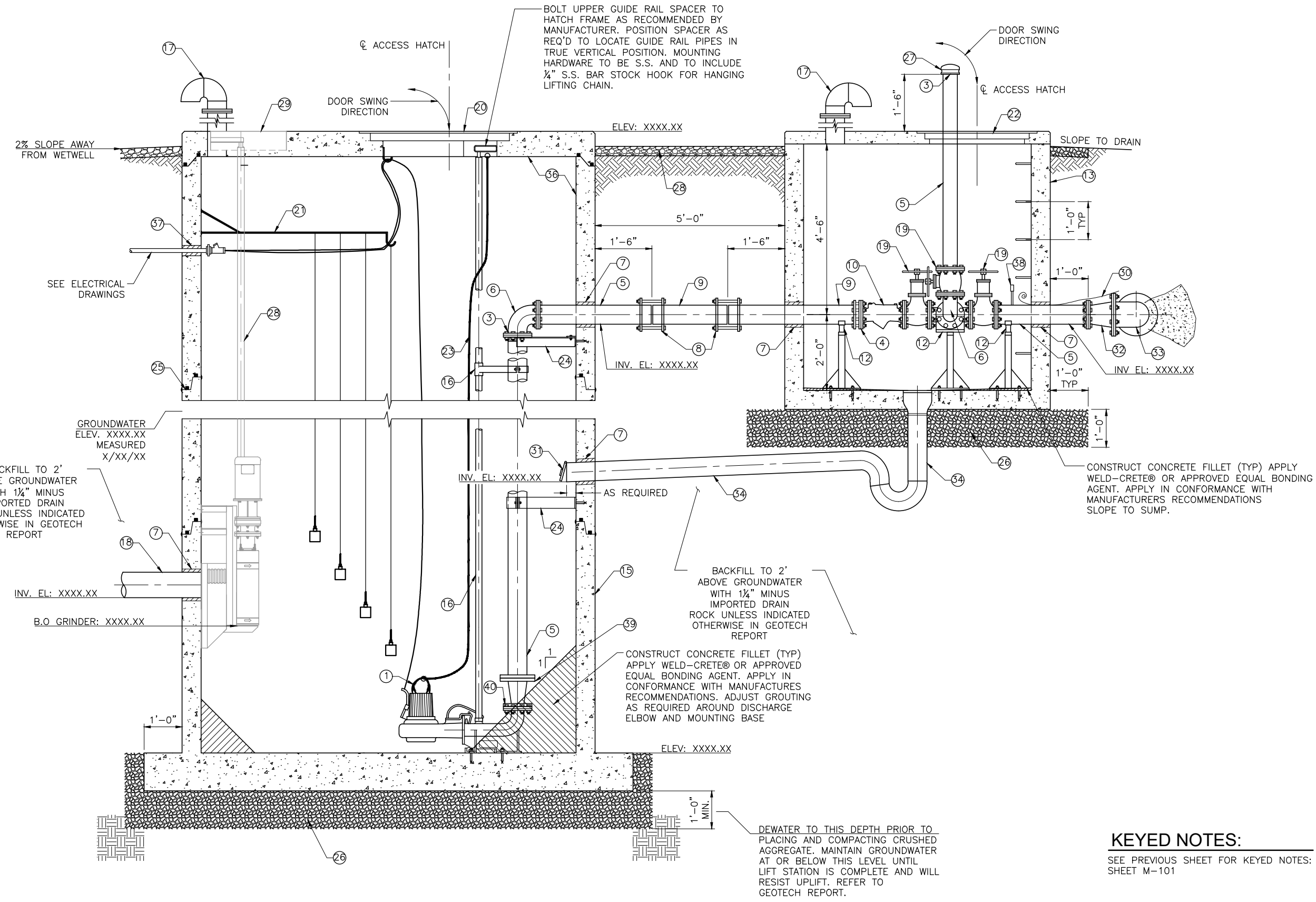

KEYED NOTES:
 SEE PREVIOUS SHEET FOR KEYED NOTES:
 SHEET M-101

1 LIFT STATION-MECHANICAL SECTION
 SCALE: 3/4"=1'

Plot Date: 1/26/2018 10:12 AM Plotted By: Jason Miller
 Date Created: 1/24/2018 File Standards: CITY STANDARDS/UPDATED STANDARDS/HOOPER-LUB/LIFT STATION.DWG

REUSE OF DRAWINGS AND THE IDEAS AND DESIGNS INCORPORATED HEREIN ARE THE PROPERTY OF J-U-B ENGINEERS, INC. AND IS NOT TO BE USED IN WHOLE OR PART FOR ANY OTHER PROJECT WITHOUT THE EXPRESS WRITTEN AUTHORIZATION OF J-U-B ENGINEERS, INC.

NO.	REVISION	DESCRIPTION	BY	APPR.	DATE

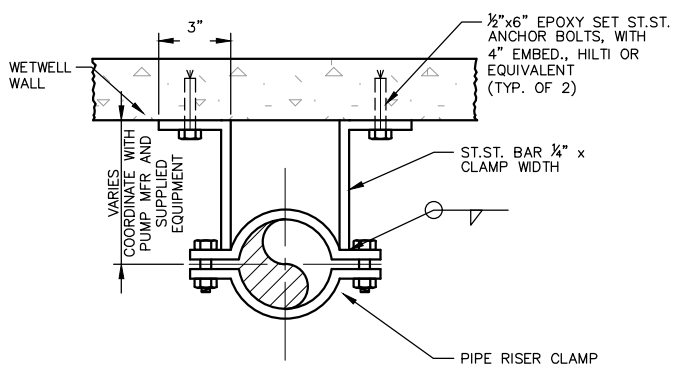

PLAN VIEW

- NOTES:**
1. MATERIALS TO BE STAINLESS STEEL
 2. USE WHERE REQUIRED THRUST RESTRAINT IS MINIMAL.

1 PIPE BRACE DETAIL
 SCALE: N.T.S

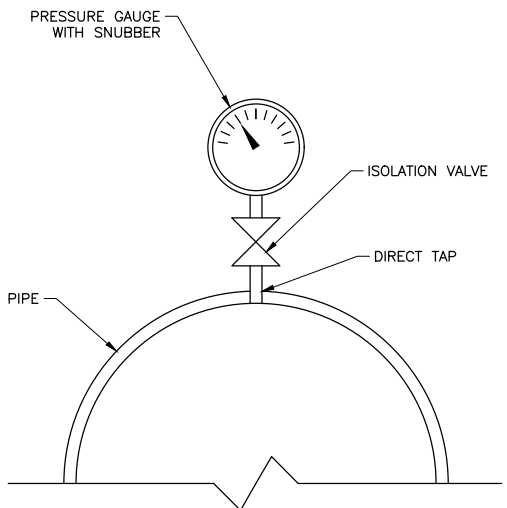

2 PRESSURE GAUGE ASSEMBLY
 SCALE: N.T.S

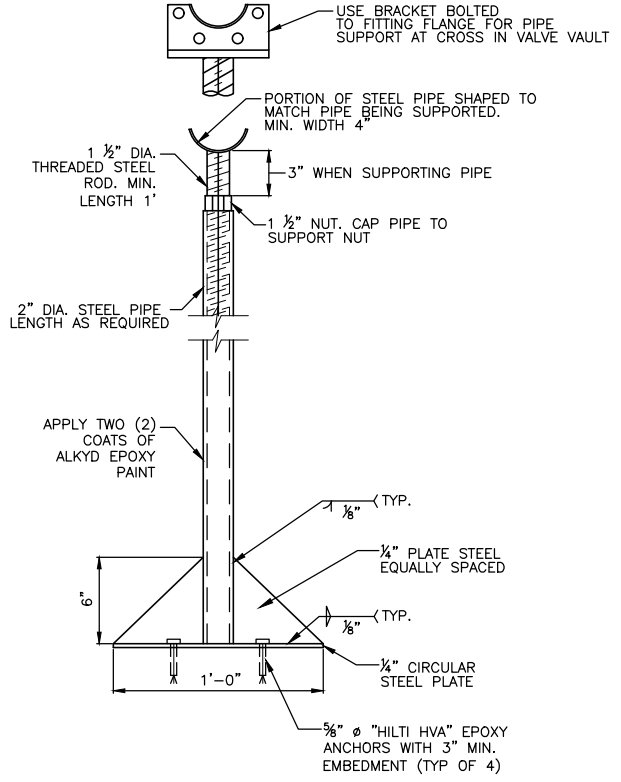

3 TYP. STEEL PIPE SUPPORT DETAIL
 SCALE: N.T.S

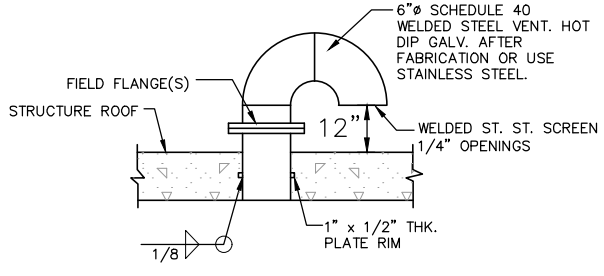

4 SCREENED VENT DETAIL
 SCALE: N.T.S

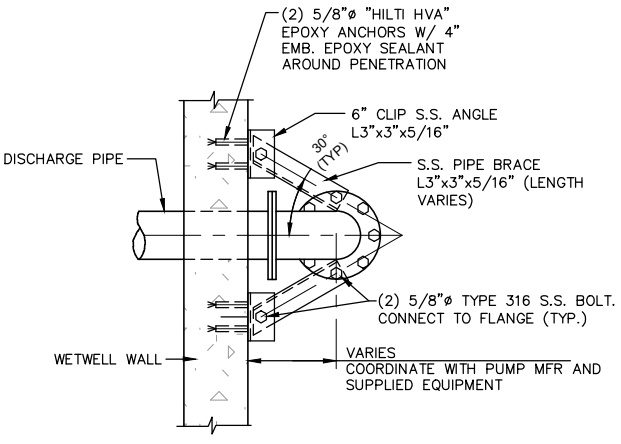

PLAN VIEW

- NOTES:**
1. MATERIALS TO BE STAINLESS STEEL
 2. TOP SUPPORT MUST PROVIDE THRUST RESTRAINT.

5 THRUST RESTRAINT PIPE SUPPORT DETAIL
 SCALE: N.T.S

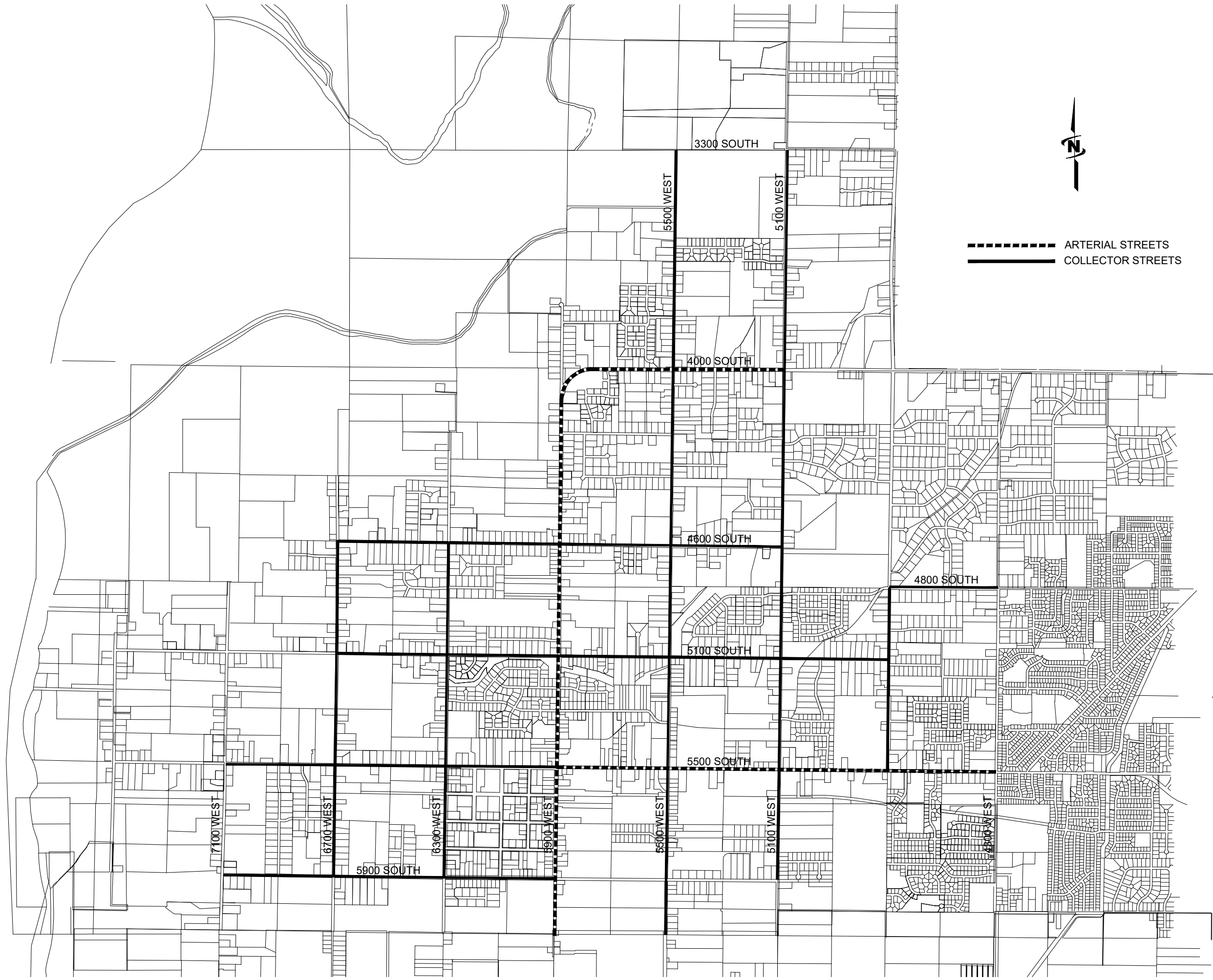

----- ARTERIAL STREETS
 _____ COLLECTOR STREETS



PRELIMINARY
 PLANS
 NOT FOR
 CONSTRUCTION

THIS DOCUMENT AND THE IDEAS AND DESIGNS INCORPORATED HEREIN ARE THE PROPERTY OF J-U-B ENGINEERS, INC. NO PART OF THIS DOCUMENT IS TO BE REPRODUCED OR TRANSMITTED IN ANY FORM OR BY ANY MEANS, ELECTRONIC OR MECHANICAL, WITHOUT THE EXPRESS WRITTEN AUTHORIZATION OF J-U-B ENGINEERS, INC.

NO.	REVISION	DESCRIPTION	BY	DATE

HOOPER CITY STREET CLASSIFICATION MAP
 HOOPER CITY
 DEVELOPMENT STANDARDS